



Important

Please open this form in Adobe Acrobat.
It has interactive elements which may not function correctly
if opened in your web browser.

If you don't have Adobe Acrobat Reader installed, you can download it here:

<https://get.adobe.com/reader/>

Bivona™ Customized FlexTend™ Tracheostomy Tube Template

1. Shaft Length

1a. Shaft Length _____ mm (5 mm min, 60 mm max)

1b. Shaft Length _____ mm (30 mm min, 140 mm max)

2. Shaft

I.D.	O.D.	I.D.	O.D.	I.D.	O.D.	I.D.	O.D.	I.D.	O.D.
<input type="radio"/> 2.5	4.0	<input type="radio"/> 4.0	6.0	<input type="radio"/> 5.5	8.0	<input type="radio"/> 7.0	10.0	<input type="radio"/> 8.5	11.8
<input type="radio"/> 3.0	4.7	<input type="radio"/> 4.5	6.7	<input type="radio"/> 6.0	8.7	<input type="radio"/> 7.5	10.4	<input type="radio"/> 9.0	12.3
<input type="radio"/> 3.5	5.3	<input type="radio"/> 5.0	7.3	<input type="radio"/> 6.5	9.4	<input type="radio"/> 8.0	11.0	<input type="radio"/> 9.5	13.3

3. Connector (check one box only)

- 3a. Swivel 2.5–9.5 mm 3b. Fixed 2.5–6.0 mm

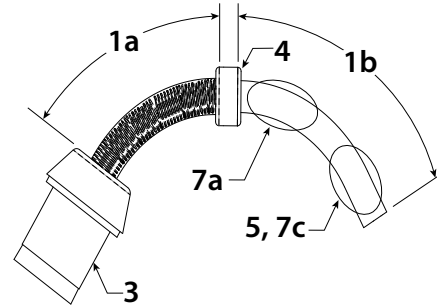
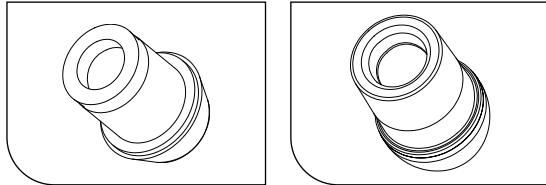

4. Neck Flange (check one box only)

- 4a. 2.5–6.0 mm 4c. 2.5–9.5 mm 4d. 6.5–9.5 mm 4e. 2.5–4.0 mm 4f. 2.5–6.0 mm

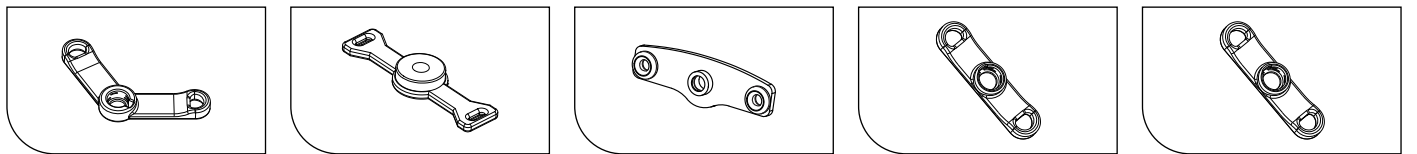

Neck Flange Length: 60 mm

Neck Flange Length: 83 mm

Neck Flange Length: 67 mm

Neck Flange Length: 47 mm

Neck Flange Length: 60 mm

5. Cuff (check one box only)

- 5a. TTS Tight to Shaft 5b. Aire-Cuf™ Pedi 5b. Aire-Cuf Adult 5c. Fome-Cuf™ Adult 5d. Cuffless

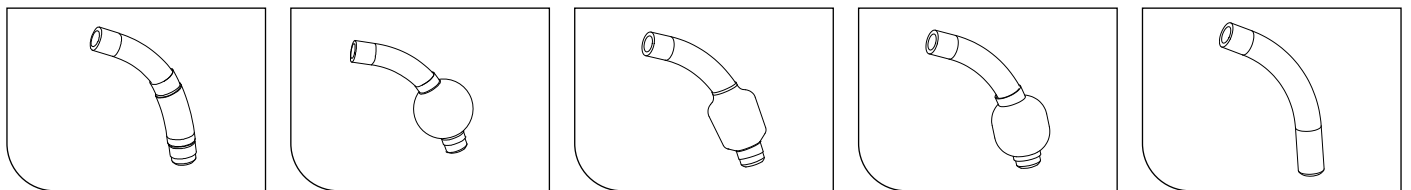

2.5–9.5 mm

2.5–5.5 mm

5.0–9.5 mm

2.5–9.5 mm

2.5–9.5 mm

6. Shaft Option

- 6a. Shaft (Only proximal section is wire reinforced.)

- 6b. Hyperflex

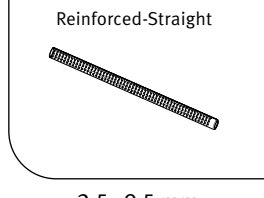
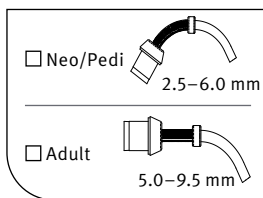

2.5–9.5 mm

7. Optional

- 7a. Proximal (Top) Cuff 7b. Stoma Seal 7c. Distal (Bottom) Cuff

- TTS Cuff Solid Silicone
 Aire-Cuf _____ mm O.D.
 Fome-Cuf _____ mm Length
 Pediatric
 Adult
Cuff position from Neck Flange _____ mm
Note: Minimum distance 2 mm Tapered
 Non Tapered

Cuff distance from tip to shaft _____ mm
Note: Cuff distance from tip cannot be less than the minimum standard distance listed below:
a. Pediatric TTS, Aire-Cuf & Fome-Cuf – 3 mm
b. Adult Aire-Cuf & Fome-Cuf – 5 mm
c. Adult TTS – 9 mm

- 7d. Talk Attachment

5.0 mm I.D. Adult shaft or above only

8. Approval Please note: ICU Medical will review the completed template for compliance.

Any required modifications will be made with the approval of a clinician.

Hospital/Clinic _____

Clinician Name _____ Clinician Title _____

P.O. Number _____ Date _____

9. Select Type of Service

- Extended next day service (non-sterile), same day shipping if order received by 12 noon (CST) USA only
- Standard service (sterile) Express service (non-sterile)
- Standard service (non-sterile) Next day service (non-sterile) USA only



Phone: 1-800-424-8662

Fax: 219-989-7435

Email: bco@icumed.com

Web: www.icumed.com