

System Operating Manual



For Infusion Systems with v11.6 Software

*For use with Lists: 12391-04, 12618-04,
12348-04, & 11971-04*

Back
Prime



A



B



Options/
Vol Inf



*HOSPIRA, INC., 275 NORTH FIELD DRIVE,
LAKE FOREST, IL 60045, USA
430-95215-009 (A, 2015-06)*

Change History

Title	Description of Change	Section
430-95215-006 (Rev. 2011-04)	Sixth Release	All
430-95215-008 (Rev. 2013-02)	Replaced ® with ™, removed copyright and trademark statements, updated regulatory symbols	All
	Added precaution to prevent unrestricted flow	1 and 2
	Rewrote air bubble precaution and air filter recommendation. Added low flow rate range	1
	Updated alarm volume instructions	3
	Added administration set graphic and warning to prevent unrestricted flow	4
	Added instructions for closing clamps	4 and 5
	Updated air in line alarm distal and cumulative bolus amounts	9
430-95215-009 (A, 2015-06)	Deleted "All Rights Reserved"	TOC
	Updated "Technical Support Operations" to "Advanced Knowledge Center"	Inside back cover

Title	Description of Change	Section
	Revised power requirements, generalized fuse information, and added low flow rate delivery accuracy statement	9

NOTES

Contents

1) DESCRIPTIVE INFORMATION	1-1
1.1 PRODUCT DESCRIPTION	1-3
1.2 INDICATIONS FOR USE	1-3
USER QUALIFICATION	1-3
1.3 CONVENTIONS	1-4
WARNINGS, CAUTIONS, AND NOTES	1-5
1.4 PRECAUTIONS	1-6
ARTIFACTS	1-6
HEALTHCARE PROFESSIONALS AND PATIENT RELATED ..	1-7
CONCURRENT FLOW	1-9
EPIDURAL ADMINISTRATION	1-11
BATTERY OPERATION	1-12
SETS AND ACCESSORIES	1-12
BACKPRIMING	1-13
GENERAL	1-13
CLEANING	1-13
BOLUS RELATED	1-14
2) PRINCIPLES OF OPERATION	2-1
2.1 FEATURES	2-1
PROGRAMS	2-1
LINE PROGRAMMING OPTIONS	2-1
PLUMSET CAPABILITIES	2-2
AIR MANAGEMENT	2-2
BATTERY	2-2
BIO MEDICAL	2-2
OPTIONS	2-2
OTHER FEATURES	2-3
2.2 DEFINITIONS	2-3

3) EQUIPMENT DESCRIPTION 3-1

3.1 OPERATING KEYS 3-2

3.2 INDICATORS 3-5

3.3 REAR CASE CONTROLS 3-6

3.4 ADMINISTRATION SETS 3-8

 PREPARING THE ADMINISTRATION SET 3-9

 PRIMING THE ADMINISTRATION SET 3-10

 LOADING THE CASSETTE 3-10

 PREPARING THE SECONDARY LINE 3-11

3.5 DISCONTINUING ELECTRONIC FLOW CONTROL
AND SETTING GRAVITY FLOW 3-13

3.6 DISCONTINUING FLUID ADMINISTRATION 3-14

4) BASIC OPERATION 4-1

4.1 GETTING STARTED 4-1

 UNPACKING 4-1

 TANDEM CARRIER INSTRUCTIONS 4-2

 SYSTEM SELF-TESTS 4-2

 DATA RETENTION 4-4

4.2 POWER ON 4-4

4.3 SIMPLE DELIVERY 4-6

4.4 TITRATION 4-9

4.5 PIGGYBACK DELIVERY 4-12

4.6 CONCURRENT DELIVERY 4-14

4.7 STOP AND START WITH ONLY 1 LINE PUMPING . . 4-17

4.8 STOP AND START WITH BOTH LINES PUMPING . . 4-18

4.9 BACKPRIMING 4-20

4.10 CLEARING PROGRAM SETTINGS 4-21

4.11 CLEARING PROGRAM SETTINGS WHEN
BOTH LINES ARE PROGRAMMED 4-23

5) THERAPIES 5-1

5.1 DOSE CALC (MCG/KG/MIN ON A) 5-2

5.2 DOSE CALC (MG/MIN ON B) 5-8

5.3 LOADING DOSE 5-14

5.4 MULTISTEP PROGRAMMING 5-21

6) ADDITIONAL FEATURES	6-1
6.1 SIMPLE DELIVERY USING DRUG LIST	6-1
6.2 SIMPLE DELIVERY USING DELAYED START	6-4
6.3 PIGGYBACK WITH NURSE CALLBACK	6-5
6.4 POSSIBLE NON-DELIVERY PROGRAMMED	6-7
6.5 USING THE STANDBY FEATURE	6-7
6.6 SELECT OPTION - VOLUMES INFUSED, PRESSURE/POST INFUSION RATE, AND LIGHTING/CONTRAST	6-9
6.7 VARIABLE RATE CAP	6-13
6.8 EXAMPLES OF AUTOMATIC CALCULATION	6-13
AT STARTUP	6-13
WHILE RUNNING (TITRATION)	6-13
AT KVO	6-14
7) ALARMS AND TROUBLESHOOTING	7-1
7.1 WARNING MESSAGES	7-1
7.2 RESPONSE TO ALARMS	7-2
GENERAL ALARMS	7-3
LINE A ALARMS	7-5
LINE B ALARMS	7-6
MALFUNCTIONS	7-7
8) MAINTENANCE AND STORAGE	8-1
8.1 CLEANING, MAINTENANCE, AND STORAGE	8-1
CLEANING AND SANITIZING	8-1
BATTERY MAINTENANCE	8-3
STORAGE	8-4
SERVICE	8-4

- 9) SPECIFICATIONS 9-1**
 - PHYSICAL 9-1
 - ELECTRICAL 9-1
 - VTBI RANGE 9-2
 - ENVIRONMENT 9-2
 - DELIVERY RATE RANGE 9-2
 - AIR-IN-LINE ALARM 9-3
 - OCCCLUSION ALARM AND LIMITS 9-3
 - TIME TO DETECT DOWNSTREAM OCCCLUSIONS 9-4
 - BOLUS VOLUME RELEASED AFTER DOWNSTREAM
OCCCLUSIONS ARE CORRECTED 9-4
 - DELIVERY ACCURACY 9-4
 - ENTERAL AND HIGH VISCOSITY FLUIDS EFFECTS 9-5
 - TRUMPET CURVES 9-6
 - EXAMPLE 9-6

- 10) SUPPLIES AND ACCESSORIES 10-1**
 - 10.1 ADMINISTRATION FLUIDS 10-1
 - ADMINISTRATION FLUIDS 10-1
 - ENTERAL AND HIGH VISCOSITY FLUIDS 10-1
 - CONTAINERS 10-1
 - 10.2 ACCESSORIES 10-2

- 11) WARRANTY 11-1**

- 12) DRUG LIST 12-1**

1) Descriptive Information

NOTE: In this manual, references to Plum A+™ apply to both systems unless otherwise noted.

**Plum A+™
Lists # 12391-04
and 11971-04**



**Plum A+™ 3
Lists # 12618-04
and 12348-04**

**CAUTION: THIS
DEVICE IS TO BE USED
WITH AN IV POLE WITH
A 6-WHEEL BASE AND
A SHELF.**



The Plum A+ and Plum A+3 Volumetric Infusion Systems are designed to meet the fluid delivery requirements of today's evolving healthcare environments. Both are cassette based multi-function infusion systems. The Plum A+ allows two lines in and one line out while the Plum A+3 allows six lines in and three lines out. Each pump can be used for standard, piggyback, or concurrent delivery. Therapy modes include:

- Standard Infusions
- Multistep Programming
- Loading Dose
- Dose Calculation

The Plum A+ and Plum A+3 are designed to deliver parenteral, enteral, or epidural infusions over a broad range of infusion rates from multiple fluid container types.

Both are designed to be used in most areas of patient care, including, but not limited to:

- | | | |
|---------------------------|--|------------------------------------|
| • <i>General Floor</i> | • <i>Labor/Delivery/
Post Partum</i> | • <i>Burn Unit</i> |
| • <i>Medical/Surgical</i> | • <i>OR/Anesthesia</i> | • <i>Hemodialysis</i> |
| • <i>ICU/CCU</i> | • <i>Post Op/
Recovery</i> | • <i>Oncology</i> |
| • <i>Pediatrics</i> | • <i>Cardiac Cath Lab</i> | • <i>Mobile Intensive
Care</i> |
| • <i>Neonatology</i> | • <i>Emergency</i> | • <i>Nutritional</i> |

1.1 Product Description

Each system includes a pumping module (hereafter called the infuser) and an assortment of disposable IV sets (hereafter called a set), optional accessories, and this operator's manual.

A computer dataport is also provided to interface with a host computer.

Accessory equipment connected to the analog and digital interfaces must be certified according to the respective IEC Standards (for example, IEC 60950 for data processing equipment and IEC 60601-1 for Medical Equipment). Furthermore, all configurations shall comply with the system standard IEC 60601-1-1. Any person who connects additional equipment to the signal input or output part configures a medical system, and is therefore responsible for ensuring that the system complies with the requirements of the system Standard IEC 60601-1-1. If in doubt, consult the technical service department or your local representative.

NOTE: Do not connect dataport while infusing.

1.2 Indications for Use

USER QUALIFICATION

The Plum A+ is intended for use at the direction or under the supervision of licensed physicians or certified healthcare professionals who are trained in the use of the infuser and the administration of parenteral, enteral, and epidural fluids and drugs and whole blood or red blood cell components. The training should emphasize preventing related IV complications, including appropriate precautions to prevent accidental infusion of air. The epidural route can be used to provide anesthesia or analgesia.

WARNING

ADMINISTER ONLY ANESTHETICS/ANALGESICS APPROVED FOR EPIDURAL ADMINISTRATION (AS INDICATED OR ALLOWED BY THE DRUGS' FDA APPROVED LABELING). EPIDURAL ADMINISTRATION OF DRUGS OTHER THAN THOSE INDICATED FOR EPIDURAL USE COULD RESULT IN SERIOUS INJURY TO THE PATIENT.

1.3 Conventions

This section describes the conventions used throughout this manual, as follows:

CONVENTION	APPLICATION	EXAMPLE
<i>Italic</i>	Reference to a section, figure, or table Function or mode specific instructions	(See Figure 3-1, Priming Cassette) <i>Primary Only:</i> Attach an empty container.
[BRACKETED ALL CAPS]	Keys or buttons on the device are displayed in [BRACKETED ALL CAPS] or with a graphic.	[START] or 
▲ [<i>Italic</i>]	Softkey Options	▲ [<i>Choose</i>]
Initial Caps lowercase	Screen displays and device labels (as appropriate)	Therapy Dose Calculation
Bold	Emphasis	...sets are supplied Sterile and are for....

WARNINGS, CAUTIONS, AND NOTES

Alert messages used throughout this manual are described below. Pay particular attention to these messages.

WARNING

A WARNING MESSAGE CONTAINS SPECIAL SAFETY EMPHASIS AND MUST BE OBSERVED AT ALL TIMES. FAILURE TO OBSERVE A WARNING MESSAGE IS POTENTIALLY LIFE THREATENING.

CAUTION: A CAUTION USUALLY APPEARS IN FRONT OF A PROCEDURE OR STATEMENT. IT CONTAINS INFORMATION THAT COULD PREVENT IRREVERSIBLE PRODUCT DAMAGE OR HARDWARE FAILURE. FAILURE TO OBSERVE A CAUTION COULD RESULT IN SERIOUS PATIENT OR USER INJURY.

NOTE: A Note highlights information that helps explain a concept or procedure.



This symbol directs the user to consult accompanying documents.

NOTE: Figures are rendered as graphic representations to approximate the actual product. Therefore, figures may not exactly reflect the product.

1.4 Precautions

The Plum A+ has been designed and manufactured to be safe, reliable, and easy to use. This section details precautions and possible hazards.

For safe operation of the Plum A+, observe the following precautions and hazards.

ARTIFACTS

- Nonhazardous, low-level electrical potentials are commonly observed when fluids are administered using infusion devices. These potentials are well within accepted safety standards, but may create artifacts on voltage-sensing equipment such as ECG, EMG, and EEG machines. These artifacts vary at a rate that is associated with the infusion rate. If the monitoring machine is not operating correctly or has loose or defective connections to its sensing electrodes, these artifacts may be accentuated so as to simulate actual physiological signals. To determine if the abnormality in the monitoring equipment is caused by the infusion device instead of some other source in the environment, set the infusion device so that it is temporarily not delivering fluid. Disappearance of the abnormality indicates that it was probably caused by the electronic noise generated by the infusion device. Proper setup and maintenance of the monitoring equipment should eliminate the artifact. Refer to the appropriate monitoring equipment system documentation for setup and maintenance instructions.
- The Plum A+ system is designed to operate normally in the presence of most encountered electromagnetic interference (EMI) conditions. In the event of extreme levels of interference, such as encountered next to an electrosurgical generator, it is possible that the normal operation of a sensor or microcomputer might be

disrupted. Even in this event, the outcome would likely be a false alarm or detected system malfunction and would not result in a hazard to patient or operator.

- Use of radio frequency emitting devices such as cellular telephones and 2-way radios in close proximity of this device may affect its operation.

HEALTHCARE PROFESSIONALS AND PATIENT RELATED

- Setting the primary rate greater than the secondary rate will result in a more rapid infusion of any residual secondary drug remaining in the line and the cassette.
- Consult drug labeling to confirm drug compatibility, concentration, delivery rates, and volumes are all suitable for secondary, concurrent and piggyback delivery modes.
- Arrange tubing, cords, and cables to minimize the risk of patient strangulation or entanglement.
- Before opening the door, close clamp on the primary line or remove the secondary container from the secondary port to prevent mixing of primary and secondary fluids.
- To prevent unrestricted flow, close all slide or CAIR™ clamps before opening the cassette door.
- Although unlikely, failure of certain robust mechanical components such as the anti-free flow mechanism or valve control springs could cause fluid delivery limited to the contents of the fluid container. Single fault failure of certain electronic/motor control components would result in no more than 5 mL of unexpected fluid delivery.
- A small amount of fluid is expelled from the set (less than 0.05 mL) each time the door is opened or closed with a set installed. If potent drugs are being used, take appropriate action to guard against overmedication of the patient.

- Before disconnecting a syringe from the cassette, pull up the plunger slightly to avoid spilling the fluid. For rigid containers, close the upper slide clamp, open the cassette door, then remove and invert the cassette (ports down).
- Air bubbles may form distal to the cassette as a result of normal out-gassing of dissolved air in the fluid in one or more of the following cases:
 - Chilled solution is in use
 - Certain fluids known to routinely outgas are in use
 - The infuser is mounted significantly above the patient
 - The infuser is infusing at very low rates between 0.1– 5 mL/hr

In these cases an air-eliminating filter may be used when clinically appropriate.

- Repeated opening and closing of the door may defeat the proximal air-in-line alarm and may cause a distal air-in-line alarm, requiring repriming.
- In vitro studies have suggested that packed red blood cells with unusually high hematocrit be diluted with blood-compatible fluids, such as 0.9% sodium chloride injection, to decrease hemolysis and increase flow rate.
- The screen displays the VTBI (volume to be infused) in integers when value is above 99.9. Any fraction of a milliliter delivered is not displayed, but is retained in memory.
- For Plum A+3 users, be aware that changing the weight on one device does NOT change the weight on the other two devices. Patient weight must be changed on each device when delivering weight-based therapy dependent on medication requirements.

CONCURRENT FLOW

GUIDELINES

When delivering short half-life critical drugs (*see Critical Drugs, this section*) using the Plum A+ in the Concurrent mode, the following delivery rate guidelines should be observed:

- If the critical drug (with half-life less than 6 minutes) is to be infused at less than 2 mL/hr, the other infusion should be no faster than 5 times the critical drug's rate. Dopamine, for example, delivered at 1.5 mL/hr should not be accompanied by an infusion programmed any faster than 7.5 mL/hr.
- If the critical drug (with half-life less than 6 minutes) is to be infused at 2 to 5 mL/hr the other infusion should be no faster than ten times the critical drug's rate. Dopamine, for example, delivered at 3.5 mL/hr should not be accompanied by an infusion programmed any faster than 35 mL/hr.
- If the critical drug (with half-life less than 6 minutes) is to be infused at 5.1 mL/hr or greater, the other infusion can be programmed at any desired rate.

NOTE: The total of the primary rate plus the secondary rate cannot exceed 500 mL/hr.

These guidelines apply *only* when infusing *short half-life critical drugs* in *Concurrent mode*. Individual patient responses may vary requiring adjustment of delivery rates.

DELIVERY RATE GUIDELINES	
SHORT HALF-LIFE (LESS THAN 6 MINUTES) CRITICAL DRUG INFUSION RATE	MAXIMUM RATE OF ACCOMPANYING INFUSION
0.5 - 1.9 mL/hr	5 Times the Critical Drug Rate
2 - 5 mL/hr	10 Times the Critical Drug Rate
5.1 or Greater	Any Desired Ratio

CRITICAL DRUGS

Examples of drugs with a short half-life (approximately 6 minutes or less when given IV) include:

Dobutamine	Lidocaine
Dopamine	Nitroglycerin
Epinephrine	Nitroprusside
Epoprostenol	Norepinephrine
Esmolol	Oxytocin
Isoproterenol	Procainamide

For these drugs, the concurrent flow guidelines should be followed when the infusion rate of the drug will be 5 mL/hr or less.

NOTE: This list of critical drugs is not intended to be all-inclusive of critical drugs or drugs with a short half-life.

The clinician should become familiar with the pharmacodynamics of any critical drug before administration.

This information is presented to inform clinicians of a rare situation that could be misinterpreted if they are unfamiliar with this phenomenon.

EPIDURAL ADMINISTRATION

- Recommended use of the epidural route is to provide anesthesia or analgesia for periods up to 96 hours.
- This device can be used to administer only those anesthetics/analgesics approved for epidural administration (as indicated or allowed by the drugs' FDA approved labeling). Epidural administration of drugs other than those indicated for epidural use could result in serious injury to the patient.
- For epidural administration, the use of Hospira catheters, PlumSets™ without Y-sites, and "epidural" stickers indicating ongoing epidural administration are recommended.
- Administration of drugs via the epidural route should be limited to personnel familiar with associated techniques and patient management problems. Proper epidural placement of the catheter is essential since catheter migration could result in intravascular or intrathecal administration. Facilities practicing epidural administration must be equipped with resuscitative equipment, oxygen, naloxone, and other resuscitative drugs. Adequate monitoring equipment (for example, Oximetry) is recommended for continuous monitoring of the patient during epidural administration. Patients must be observed frequently for side effects in a fully-equipped and staffed environment for at least 24 hours following completion of drug administration by the epidural route. **DELAYED RESPIRATORY DEPRESSION FOLLOWING CONTINUOUS EPIDURAL ADMINISTRATION OF PRESERVATIVE-FREE MORPHINE SULFATE HAS BEEN REPORTED.**
- The epidural space has 58 openings through which fluid can exit. Pressure buildup during administration is transient. However, if a large volume of fluid is administered over a short time period, the pressure will take longer to return to normal. If overdelivery occurs during administration, observe the patient closely for signs of spinal cord compression (disorientation, headache, transient neuralgias) and drug overdose.

BATTERY OPERATION

- Do not operate the Plum A+ on patients when the battery is removed. Use of a properly maintained and charged battery helps confirm proper operation.
- The battery may not be fully charged upon receipt. Connect the infuser to AC power for at least six hours.
- Use AC power whenever possible. Connect to AC power during storage to ensure a fully charged battery for emergencies. If quality earth grounding source is in doubt, use battery power.
- If the low-battery alarm sounds, connect the infuser to AC power immediately.

SETS AND ACCESSORIES

- Only compatible LifeCare PlumSets can be used with the Plum A+. See individual set instructions for additional information.
- Administration sets should be changed per CDC guidelines or healthcare provider policy. Discard after use.
- LifeCare™ IV infusion sets with integral nonblood filters are not for use in the administration of blood, blood products, emulsions, suspensions, or any medications not totally soluble in the solution being administered. These medications may be administered through the lower Y-injection site, below the filter.
- When infusing at low delivery rates (5 mL/hr or less) the use of thick-walled microbore PlumSets is recommended. This will reduce the amount of the fluid bolus that may be delivered when a distal line occlusion is released.
- Syringes must be larger than 3 cc. Use a syringe adapter (List 11986-48) when using syringes smaller than 10cc. Some 10cc syringes may require use of a syringe adapter. Syringes larger than 10cc may be attached directly to the secondary port of the cassette. Use of a

syringe adapter may decrease the occurrence of proximal occlusion alarms.

- Use a 19-gauge or larger needle or catheter at the venipuncture site for viscous fluids if operating at rates greater than 500 mL/hr.

See *Section 10* for information on sets and accessories.

BACKPRIMING

- Backpriming is not recommended for reconstituting secondary containers containing dry powders.
- To avoid pressurization when backpriming into a syringe, the user must confirm there is sufficient empty space to accept the backprimed fluid.

GENERAL

- Possible explosion hazard exists if used in the presence of flammable anesthetics.
- Do not place Plum A+ in service if it fails the self-test.
- Do not operate the Plum A+ with the case opened.
- Keep the cassette door securely closed while the infuser is not in use, to avoid cassette door damage.
- The Plum A+3 is to be used with an IV pole with a 6-wheel base and a shelf.

CLEANING

For more information on cleaning the infuser, see *Section 8, Maintenance and Storage*.

- To avoid mechanical or electronic damage, do not immerse the Plum A+ in any fluids or cleaning solutions.
- Do not spray cleaning solutions toward any opening in the instrument.
- Certain cleaning and sanitizing solutions may slowly degrade components made from some plastic materials. Using abrasive cleaners or cleaning solutions not

recommended by Hospira may result in product damage. Do not use compounds containing combinations of isopropyl alcohol and dimethyl benzyl ammonium chloride.

- Never use sharp objects such as fingernails, paper clips, or needles to clean any part of the infuser.
- Do not sterilize by heat, steam, ethylene oxide (ETO), or radiation.
- To avoid infuser damage, cleaning solutions should only be used as directed. The disinfecting properties of cleaning solutions vary; consult the manufacturer for specific information.

BOLUS RELATED

Use the following procedure to avoid the administration of a bolus following a distal occlusion (that is, a closed distal clamp):

- If a secondary container is in use, clamp proximal tubing before opening the cassette door.
- To prevent unrestricted flow, close all slide or CAIR clamps before opening the cassette door.
- Open the cassette door and remove the cassette.
- Open the flow regulator briefly to dissipate the pressure and then close it.
- Eliminate the source of occlusion (closed clamp).
- Reinsert the cassette and close the cassette door.
- Open all clamps and resume infusion.

NOTE: When troubleshooting an occlusion where all clamps are in the OPEN position, use care to avoid delivery of a bolus by opening the flow regulator to release any built-up pressure. Close the clamp between the cassette and the patient before opening the flow regulator to relieve the pressure. See *Section 7, Alarms and Troubleshooting*, for more information.

2) Principles of Operation

2.1 Features

The Plum A+ is a dual-line volumetric infusion system designed to meet the growing demand for hospital-wide, as well as alternate site and home healthcare, standardization. With its primary line, secondary line, and piggyback fluid delivery capability, the Plum A+ is suited for a wide range of medical/ surgical and critical care applications. Full compatibility with LifeCare Plum Series administration sets and accessories and the LifeShield™ and CLAVE™ needleless protection systems, makes the Plum A+ a convenient and cost-effective infusion system.

PROGRAMS

- Dose Calculation
- Loading Dose
- Multistep Programming

LINE PROGRAMMING OPTIONS

- Drug List
- Nurse Callback
- Delayed Start Setting
- Concurrent Delivery
- Titration
- Micro 0.1-99.9 mL/hr (in 0.1 mL increments)
Flow Rate Range for Both Lines
- Macro 100-999 mL/hr (in 1 mL increments) Flow
Rate Range for Both Lines
- Automated Secondary Drug Delivery (Piggyback)
- Standby Setting

PLUMSET CAPABILITIES

- Anti Free-Flow Protection
- Direct Connection for Syringe Delivery

AIR MANAGEMENT

- Air Trap
- Air Removal/Backpriming
- Air Detection-Proximal
- Air Detection-Distal

BATTERY

NOTE: The Plum A+3 utilizes three batteries.

- Battery Gauge
- Six Hour Battery Recharge Time
- Long Battery Life (6 hours) for emergency backup and temporary portable operation

BIOMEDICAL

- Serial Communication
- Upgradability (Field- for List 12391 only)
- Variable Rate Cap
- Alarm History
- Nurse Call Relay Connector

OPTIONS

- Volumes Infused (A, B, Total Volume)
- KVO at Dose End (1 mL/hr or less depending on delivery rate) or Continue Rate (CR) to continue at the current rate
- Variable Distal Pressure Settings

OTHER FEATURES

- Nonpulsatile Volumetric Accuracy
- Microprocessor Control
- Large Liquid Crystal Display (LCD) Screen
- Panel Back Illumination on Mains Power
- Lockout Switch
- Standard Syringe Use
- Parenteral and Nonparenteral (Enteral) Fluid Delivery
- Blood and Blood Products Delivery
- Wide Range of Standard and Specialty Administration Sets
- Password Protected Keypad Lock

2.2 Definitions

TERM	DEFINITION
<i>Administration Set</i>	<i>The sterile, disposable assembly with flexible tubing that connects to a source fluid container for input to the Cassette pumping chamber and to some output device for administration to the patient.</i>
<i>Alarm</i>	<i>A condition requiring operator intervention that invokes both audible and visible alarm indicators. Confirmation of the condition usually is required.</i>
<i>Alert</i>	<i>While entering a program, a visual warning that informs the clinician of the violation of a hospital-defined rule set; for example, a dose limit for a specific drug.</i>
<i>Alternate Units</i>	<i>Dose Rate units that may be selected. Alternate Units are any units other than mL/hr.</i>

TERM	DEFINITION
<i>Alternate Units Parameters</i>	<i>Drug Amount, Diluent, Patient Weight (if applicable), and Dose Rate.</i>
<i>Backpressure</i>	<i>Resistance to fluid flow on the Distal or output portion of the Administration Set, usually expressed as mmHg.</i>
<i>Backprime</i>	<i>Removal of air or fluid from the proximal tubing and Cassette air trap by rapid pumping of fluid from Line A to an output receptacle on Line B. No fluid is delivered distal to the cassette during a Backprime.</i>
<i>Basic Delivery</i>	<i>A single-step delivery specifying rate, VTBI, and duration only. Drug name may or may not be specified.</i>
<i>Biomed Mode</i>	<i>The name for the non-delivery or service mode of Infuser operation.</i>
<i>Bolus</i>	<i>A single uninterrupted discrete volume of fluid delivered over a discrete period of time.</i>
<i>Cassette</i>	<i>A Hospira standard Plum Macro Cassette that contains the actual pumping chamber with inlet and outlet valves. It also contains access ports to diaphragms for proximal and distal line pressure sensing and chambers for air trapping and air quantity measurement.</i>
<i>Caution</i>	<i>Contains information which could prevent hardware failure, irreversible damage to equipment, or loss of data.</i>
<i>Channel</i>	<i>Distal Line output to the patient.</i>
<i>Cleared Program</i>	<i>Same as Cleared Settings, but restricted to the program delivery settings for an individual line.</i>
<i>Cleared Settings</i>	<i>Programmed delivery settings for both lines and the general control parameters are at their default values.</i>

TERM	DEFINITION
<i>Concentration</i>	<i>For Dose Calculation based Line A or B delivery programming of premixed drugs, the concentration consists of Drug Amount (in micrograms [mcg], milligrams [mg], grams, milliequivalents [mEq], millimoles [mmols], or units [USP Units]) and Diluent (Volume in milliliters [mL]). Abbreviated on screen displays as "Conc".</i>
<i>Concurrent Delivery</i>	<i>Simultaneous delivery of two fluids at independent flow rates.</i>
<i>Concurrent Mode</i>	<i>The Line B control selection mode that allows either Line A or Line B (or both) of the Mechanism to be programmed for delivery that completes with KVO or CR. Line A operation is unaffected by Line B delivery.</i>
<i>Continue Rate (CR)</i>	<i>An option used to provide fluid delivery at the current fluid delivery rate when the VTBI becomes zero.</i>
<i>Default Drug Library (DDL)</i>	<i>A drug list of 99 drug names, default units and default concentrations, plus 'No Drug Selected'.</i>
<i>Deliver Together</i>	<i>A Biomed Delivery option setting, which selects default of Piggyback or Concurrent delivery mode.</i>
<i>Delivery Mode</i>	<i>The normal operational mode for the Infuser, either Concurrent or Piggyback, during which fluid delivery may occur.</i>
<i>Delivery Rate</i>	<i>The delivery rate (as Volume/Time) assigned by the operator or calculated from other delivery parameters.</i>
<i>Device</i>	<i>The Plum A+ IV Infusion Device (Infuser), not including the disposable administration sets.</i>

TERM	DEFINITION
<i>Diluent (Volume)</i>	<i>The volume of fluid used with the Diluent Unit (for example, 250 mL), which dilutes the drug to be infused.</i>
<i>Distal</i>	<i>Downstream (output) from the Cassette portion of the Administration Set.</i>
<i>Door</i>	<i>The lever-operated, bottom-hinged, Cassette holder on the front of the Mechanism.</i>
<i>Dose (Rate)</i>	<i>Delivery rate times drug concentration.</i>
<i>Dose Calculation</i>	<i>Allows programming Dose Rates in alternative units of measure. Dose Calculation can be used in Simple Delivery, Loading Dose, and Multistep.</i>
<i>Drug Amount</i>	<i>The mass or quantity of the drug premixed with a Diluent to express the Concentration for the Line being programmed.</i>
<i>Duration</i>	<i>The time period used to deliver a VTBI at an existing Delivery Rate or as set by the operator.</i>
<i>Enteral</i>	<i>Delivery via an intestinal route.</i>
<i>Error</i>	<i>A condition resulting in an audible warning and often an accompanying message, such as an invalid key press, resulting from an operator attempt to make an input that is not valid for the current operational context. Not a Malfunction.</i>
<i>Filling Head Height (FHH)</i>	<i>The gravity induced Proximal Line pressure due to fluid height in source container above the Distal Line output level.</i>
<i>Flow Rate</i>	<i>The resulting rate of fluid flow. (See Rate and Dose.)</i>

TERM	DEFINITION
<i>Fluid Delivery Begin</i>	<i>The time required, measured from the initial start of a keypad press, for a digit in the third decimal place of a scale measuring grams to change when pumping water, the delivery tube is fluid filled, and the end of the delivery tube is immersed.</i>
<i>Infuser</i>	<i>A Plum A+ device, not including the disposable administration set.</i>
<i>Initialized Position</i>	<i>The plunger is in the Plunger Park Position, and each valve is in the Valve Home Position.</i>
<i>Key</i>	<i>Any of the marked locations on the front panels intended for user input via a pressing action.</i>
<i>KVO</i>	<i>(Keep Vein Open) Internally selected minimal delivery rate, the lesser of 1.0 mL/hr or actual Rate, intended to provide sufficient fluid flow to decrease the potential for clotting at the IV infusion site.</i>
<i>Line A</i>	<i>Inlet tubing on the top center of Cassette when viewed after it has been loaded in Mechanism Door.</i>
<i>Line B</i>	<i>Inlet connector on the top right of Cassette when viewed after it has been loaded in Mechanism Door.</i>
<i>Loading Dose</i>	<i>Allows programming of an initial infusion rate for a specific volume, followed automatically by a maintenance rate from the same container (for example, a fluid challenge). If Dose Calc is used, the Loading Dose and Maintenance Dose are in the same unit of measure, over the same period of time (mcg/min), from the same container.</i>

TERM	DEFINITION
<i>Macro Cassette</i>	<i>The Plum Cassette as part of an Administration Set whose attainable delivery performance is for general purpose uses.</i>
<i>Malfunction</i>	<i>One of a number of conditions that indicate a failure of the Infuser. These conditions usually require a repair action.</i>
<i>Mechanism</i>	<i>The provider of the physical activities of: 1) valve control for Line selection and inlet to or outlet from the Cassette; 2) Plunger extension and retraction for changing fluid volume of the Cassette pumping chamber.</i>
<i>Multistep</i>	<i>Allows a sequential program to deliver up to 10 steps; fluid volumes and delivery rates may be programmed for each step. The program may be entered based on Rate and Volume or Volume and Time. If Dose Calc is used, the delivery steps are in the same unit of measure, over the same period of time, from the same container.</i>
<i>Note</i>	<i>A Note explains something new, gives tips on performing an activity, or provides a reminder of necessary preparations.</i>
<i>Parenteral</i>	<i>Delivery via other than an intestinal route, such as intravenous (IV) injection.</i>
<i>Patient Weight</i>	<i>The Alternate Units Parameter whose value entry is required with Dose rates (quantity/time) having the third parameter of weight, such as mcg/kg/min.</i>
<i>Piggyback Delivery</i>	<i>Infusion will stop Line A and infuse Line B until VTBI completes.</i>

TERM	DEFINITION
<i>Piggyback Mode</i>	<i>The Line B control selection mode that requires Line A delivery suspension while Line B delivers and then its resumption when Line B VTBI completes. If Line A is not programmed and started, Line B delivery just stops when its VTBI completes. Line A operation is delayed for duration of its interruption by Line B.</i>
<i>Plunger Park Position</i>	<i>The position of the pumping plunger that allows the cassette to be withdrawn from the Infuser without restriction, with an opened Door.</i>
<i>POST</i>	<i>Power On Self Tests. Startup initialization and test of critical hardware modules and software functions, to determine Infuser readiness for its Intended Use.</i>
<i>Power On</i>	<i>When the power is first applied to the Infuser processor. It occurs when Infuser is in the off condition and the AC power is applied or during battery operation when the ON/OFF key is pressed.</i>
<i>Pressure</i>	<i>The measured fluid pressure for Proximal Line A, Proximal Line B, or the Distal line when a fully primed administration set is loaded into a Mechanism with the Cassette Door closed.</i>
<i>Programs</i>	<i>A Concentration-based extension to basic Volume/Rate delivery for Dose Rate applications. Softkey-selected types are: 1) Standard Program for single rate delivery; 2) Loading Dose for up to two steps of delivery at differing rates; 3) Multistep for up to ten steps of delivery at differing rates. Loading Dose and Multistep include the basic Delivery Rate option.</i>

TERM	DEFINITION
<i>Protocol</i>	<i>In the medical field, hospital-approved procedures. For devices with an electronic communications interface, the format and content of messages being exchanged.</i>
<i>Proximal</i>	<i>Upstream (input, as Line A and/or B) with respect to the Cassette portion of the Administration Set.</i>
<i>Rate</i>	<i>See Delivery Rate</i>
<i>Rounding</i>	<i>To round-off to the closest whole number (for example, 25.5 would round to 26, but 25.4 would round to 25).</i>
<i>Screen</i>	<i>That active portion of the LCD assigned to a delivery or other user interactive display operation.</i>
<i>Softkey</i>	<i>A front panel key whose function label is on the bottom portion of the display screen just above its location, so that label may be changed to indicate differing key functions within the operational context of the defined screens.</i>
<i>Standard Programming</i>	<i>(see Basic Delivery)</i>
<i>Standby</i>	<i>A delivery program state that resembles a delayed start for a line in all respects, but status display of STANDBY instead of DELAYED. A press of the START key (and a Start Softkey if necessary) will begin the programmed delivery.</i>
<i>System</i>	<i>The Plum A+ Infuser system with its associated accessories and Administration Sets.</i>
<i>Truncate</i>	<i>To round-down to the last whole number (for example, 103.7 would be 103).</i>

TERM	DEFINITION
<i>Units</i>	<i>A Drug Amount (without a quantity of mass referent) adopted as the United States Pharmacopoeia (USP) standard of measure for use in a Concentration.</i>
<i>VI</i>	<i>Volume Infused.</i>
<i>VTBI</i>	<i>Volume To Be Infused – The volume of fluid or IV solution (remaining) for delivery by a program or Therapy step from a Line.</i>
<i>Warning</i>	<i>Audible indication at the defined Warning sound level, often accompanied by a brief message, to advise operator that: 1. Input was attempt to use a function in wrong sequence, with wrong values, or at wrong time (resulting in an Invalid Key Warning); 2. Input was properly related to a function (resulting in a Valid Key Warning). (The Low Battery Warning is an exception, using the Alarm Indication sound level.)</i>
<i>Weight</i>	<i>The Alternate Units Parameter whose value entry is required with Alternate Units for Dose that include /kg/.</i>

NOTES

3) Equipment Description

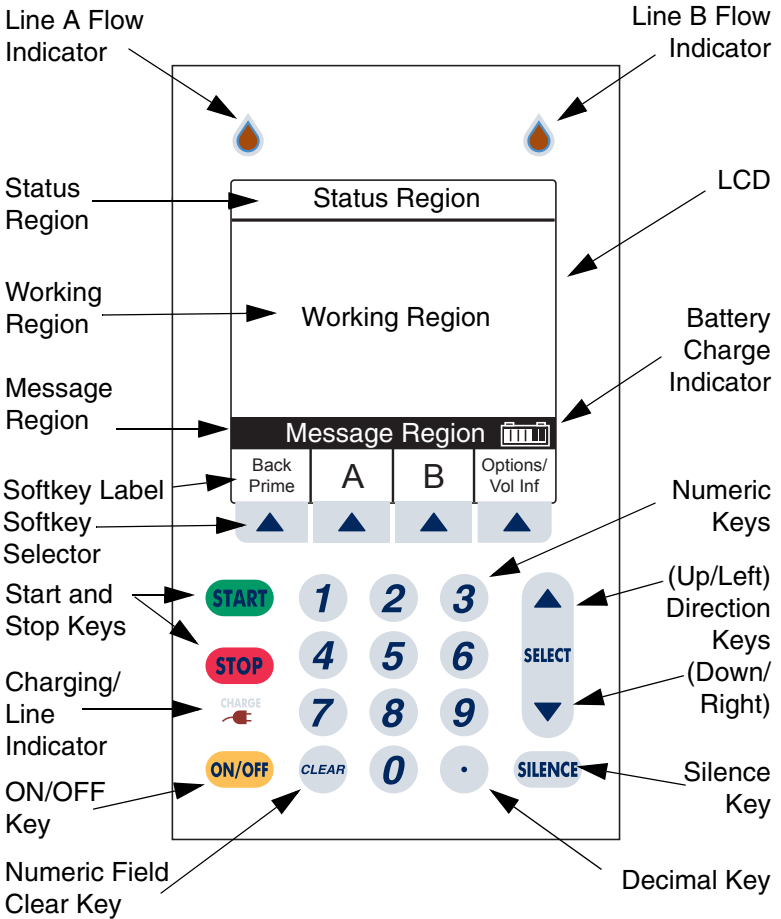

Basic Layout of Front Panel Display and Keypad

3.1 Operating Keys

NOTE: For Plum A+3, all three pumps act as individual Plum A+'s.

The [ON/OFF] key is used to control the power of the Plum A+.



NOTE: All deliveries must be stopped in order to turn the power off.

NOTE: To confirm proper shutdown of infuser, do not unplug until “**double beep**” is heard (approximately 5 seconds). If “**double beep**” is not heard, the infuser will turn itself back ON sensing the AC power was lost and revert to battery back-up power.

The [START] key is used to begin infusion and as final confirmation of programming.



The [STOP] key is used to stop the current delivery on one line; used in conjunction with soft keys to stop delivery on both lines.



The [SILENCE] key is used to silence an audible alarm during actions to correct its cause.



The [SELECT] keys (or ▲▼) are used to move the highlighting cursor between the programming fields.



The numeric keys are used to enter values for any highlighted field requiring numeric data.



The [CLEAR] key will cause a highlighted numeric field to be cleared in preparation for data entry.

The [Decimal] key is used to manually enter numbers other than whole numbers (that is, 1.2 mL).

The Softkeys are located at the bottom of the main display and serve a variety of functions. What each key does is indicated by the text in the display above the actual softkey.



3.2 Indicators

The Charge/Line Indicator is illuminated to indicate the battery is currently charging.

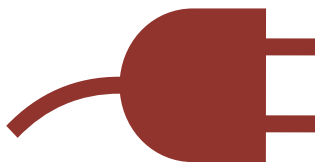

NOTE: If the device is plugged into AC power, with a battery installed, and the Charge Indicator is not illuminated, contact technical support.

The Fluid Drop Symbol, when flashing, indicates an active infusion on Line A and/or Line B.



The Battery Capacity Symbol (located on the right side of message region on display) indicates relative charge with the number of white boxes from left to right.



3.3 Rear Case Controls

NOTE: For Plum A+3, each control applies to all three pumps

The Audio Level Rotary knob is located on the back of the pump. Rotate the knob to achieve the desired alarm volume level.

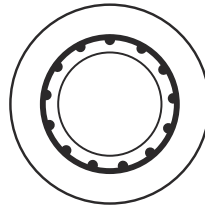

The Toggle Switch, located below the audio level control, activates the lockout function when the lever is placed in the “up” position, disabling all front panel keys except [STOP].

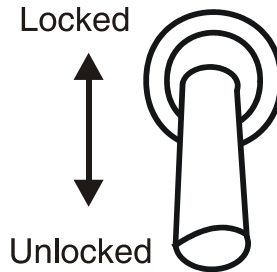

The Password Protected Keypad Lock may also be used. It both locks and unlocks the keypad by pressing the Decimal key, followed by 9, 6, and 3.



NOTE: For Plum A+3, keypad lock applies to individual pump in use.

NOTE: Pressing of a key while lockout is active results in the display of the lockout enabled message. This action is recommended to confirm each lockout activation.

NOTE: If the lockout switch is put in the “Locked” position while the infuser is off, the [ON/OFF] key allows the unit to turn on.

The connector located below the lockout switch is the Nurse Call Relay Connector, for providing remote notification of a nurse call event.



The RS-232 Dataport is used to interface with a host computer.

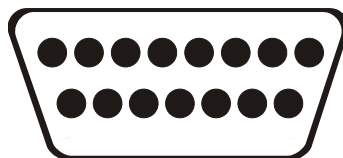

NOTE: Do not connect dataport while infusing.

The Equipotential Post (located on the back of Plum A+3) is a terminal for connection of an equipotential conductor.



3.4 Administration Sets

The Plum A+ is compatible with a wide range of LifeCare Plum series administration sets. Become familiar with the set components before preparing the administration set.

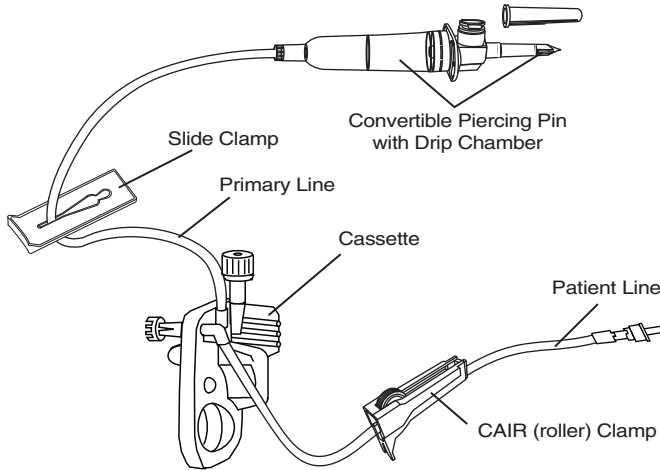

Administration Set

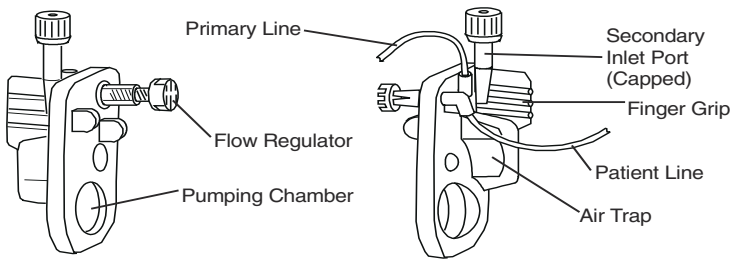

Cassette

PREPARING THE ADMINISTRATION SET

NOTE: For detailed instructions, see administration set packaging.

WARNING

ARRANGE TUBING, CORDS, AND CABLES TO MINIMIZE THE RISK OF PATIENT STRANGULATION OR ENTANGLEMENT.

Use the aseptic technique to prepare the administration set for priming, then proceed as follows:

- 1) **Make sure flow regulator is closed.**

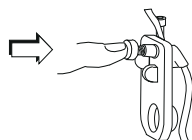

- 2) **Insert piercing pin into container outlet with a twisting motion.**



- 3) **Fill drip chamber to about 1/2 full or to the score mark. Do not completely fill.**

NOTE: To avoid getting Distal Air Alarms, confirm the fluid bag is positioned higher than the infuser. This should be set up prior to priming the cassette.

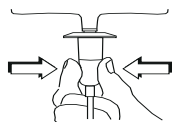

PRIMING THE ADMINISTRATION SET

- 1) Invert the cassette.

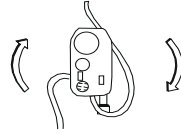

- 2) Turn the flow regulator counter-clockwise until a drop of fluid is seen in the pumping chamber.

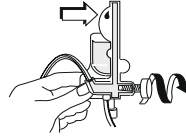

- 3) Turn the cassette upright, then prime the remainder of the administration set.

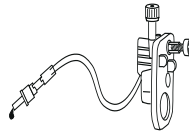

- 4) Push in the flow regulator to close. Confirm there is no flow.

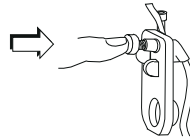

LOADING THE CASSETTE

To load the primed cassette into the plum A+, proceed as follows.

- 1) Open the cassette door by lifting up the handle.



- 2) **Insert cassette into door guides. Close the cassette door. Confirm there is no flow and no kinks appear in tubing.**

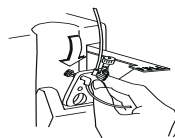

NOTE: If flow is observed, close the tubing clamps and replace the administration set.

NOTE: The administration set should be changed per CDC guidelines or healthcare provider policy. Discard after use.

PREPARING THE SECONDARY LINE

CAUTION: CONSULT THE DRUG LABELING TO CONFIRM DRUG COMPATIBILITY, CONCENTRATION, DELIVERY RATES, AND VOLUMES ARE ALL SUITABLE FOR CONCURRENT DELIVERY OR PIGGYBACK DELIVERY (SECONDARY FOLLOWED AUTOMATICALLY BY PRIMARY) MODES.

The Plum A+ features concurrent or piggyback delivery modes when therapy requires administering more than one fluid.

In addition to standard containers, the Plum A+ can use syringes on the secondary port. The secondary line can be prepared without removing or repriming the cassette.

Before preparing the secondary line, observe the following guidelines:

- **Review the backpriming function.**
- **Attach the secondary container using an 18- or 19- gauge, 31 mm (or shorter) needle, if the cassette secondary inlet port has a piercing reseal.**
- **Syringes must be larger than 3 cc. Use syringe adapter (List 11986-48) when using syringes smaller than 10cc. Some 10cc syringes may require use of a syringe adapter. Syringes larger than 10cc may be attached directly to the secondary port of the cassette. Use of a syringe adapter may**

decrease the occurrence of proximal occlusion alarms.

- **When using a syringe adapter, retract the plunger to draw approximately 1 mL of fluid into the syringe to clear air from the adapter filter.**

To prepare the secondary line, use aseptic technique and proceed as follows:

- 1) **With cassette door closed: Loosen and remove white cap, then discard. Add secondary tubing or syringe.**

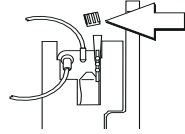

- 2) **Open all proximal clamps before pressing [START].**

- 3) **Set up per operating instructions. (See Sections 4 - 6 of this manual.)**

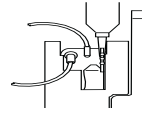

- 4) **Syringe: Secure the container to the cassette door using the optional container support arm (List 12095-03).**

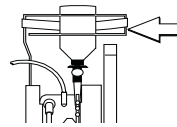

3.5 Discontinuing Electronic Flow Control and Setting Gravity Flow

If electronic flow needs to be stopped, the precision flow regulator on the cassette can be used to manually set and maintain fluid flow in a gravity mode (*see the following graphics*)

CAUTION: BEFORE OPENING DOOR, CLOSE CLAMP ON PRIMARY OR SECONDARY SET OR REMOVE SECONDARY CONTAINER FROM SECONDARY PORT TO PREVENT MIXING OF PRIMARY AND SECONDARY FLUIDS.

WARNING

TO PREVENT UNRESTRICTED FLOW, CLOSE ALL SLIDE OR CAIR CLAMPS PRIOR TO OPENING THE CASSETTE DOOR.



2 CLOSE ALL SLIDE OR CAIR (ROLLER) CLAMPS

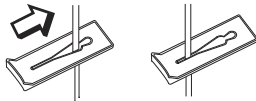

TO CLOSE SLIDE CLAMP

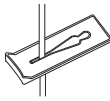

CLOSED POSITION

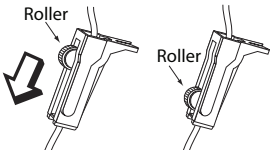

TO CLOSE CAIR (ROLLER) CLAMP

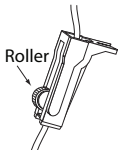

CLOSED POSITION

NOTE: IF DOOR OPEN ALARM OCCURS, TURN PUMP OFF

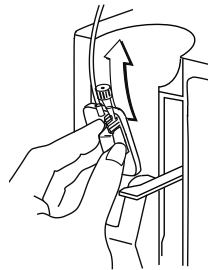

3 OPEN DOOR & REMOVE CASSETTE

NOTE: FLOW REGULATOR CLOSES AUTOMATICALLY WHEN DOOR IS OPENED TO PREVENT ACCIDENTAL FREE FLOW

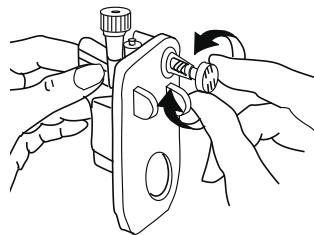

4 SET GRAVITY RATE BY TURNING FLOW REGULATOR COUNTER-CLOCKWISE

NOTE: CASSETTE SHOULD BE IN UPRIGHT POSITION AND CLAMPS SHOULD BE OPEN

3.6 Discontinuing Fluid Administration

- 1 PRESS STOP

- 2 CLOSE ALL SLIDE OR CAIR (ROLLER) CLAMPS

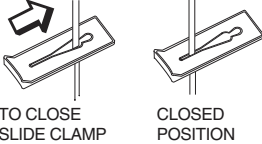

TO CLOSE SLIDE CLAMP CLOSED POSITION

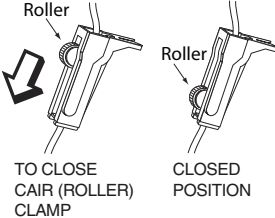

Roller TO CLOSE CAIR (ROLLER) CLAMP

Roller CLOSED POSITION
- 3 OPEN DOOR, REMOVE CASSETTE

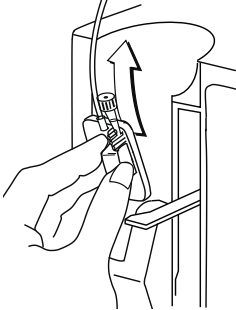

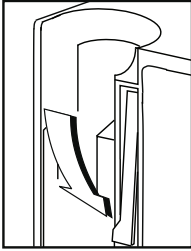
- 4 CLOSE DOOR

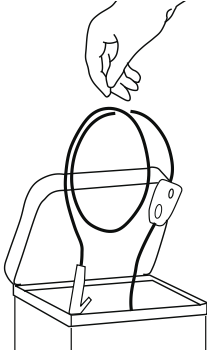
- 5 DISCARD SET AND FLUID CONTAINER PER HOSPITAL PROCEDURE

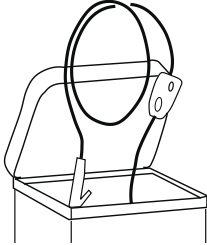

4) **Basic Operation**

4.1 Getting Started

UNPACKING

CAUTION: PRODUCT DAMAGE MAY OCCUR UNLESS PROPER CARE IS EXERCISED DURING UNPACKING AND INSTALLATION. DO NOT USE THE PLUM A+ IF IT APPEARS DAMAGED IN ANY WAY. THE BATTERY MAY NOT BE CHARGED UPON RECEIPT.

Inspect the Plum A+ packaging for possible shipping damage. If damage is found, contact the delivery company immediately.

Use care when unpacking the infuser. Retain the packing slip and save all packing material in case the infuser is damaged or fails the infuser self-test and has to be returned to Hospira.

Inspect thoroughly for damage.

CAUTION: IF THE PLUM A+ APPEARS TO BE DAMAGED, CONTACT HOSPIRA.

To set up, connect the AC (mains) cord to a properly grounded receptacle, unless temporary battery operation is desired.

NOTE: Use AC (mains) power whenever possible. Store the infuser connected to AC (mains) to confirm a fully charged battery for emergencies.

NOTE: If the quality of the earth grounding source is in doubt, use battery power.

CAUTION: THE PLUM A+ SYSTEM IS DESIGNED TO OPERATE NORMALLY IN THE PRESENCE OF MOST ENCOUNTERED ELECTROMAGNETIC INTERFERENCE (EMI) CONDITIONS. IN THE EVENT OF EXTREME LEVELS OF INTERFERENCE, SUCH AS ENCOUNTERED NEXT TO AN

ELECTROSURGICAL GENERATOR, CELLULAR TELEPHONES, OR 2-WAY RADIOS, IT IS POSSIBLE THAT THE NORMAL OPERATION OF A SENSOR OR MICROCOMPUTER MIGHT BE DISRUPTED. OPERATION OF THE INFUSER UNDER THESE CONDITIONS SHOULD BE AVOIDED.

TANDEM CARRIER INSTRUCTIONS

NOTE: The Plum A+3 is NOT to be used with the tandem carrier. It is only to be used with the Plum A+ and other single-channel devices.

The Plum A+ may be safely and conveniently mounted on an IV stand or on a tandem carrier mounted on an IV stand.

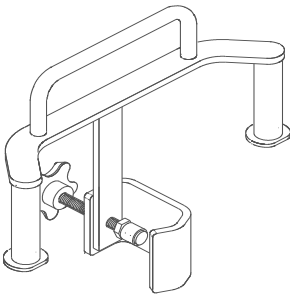

Always mount the tandem carrier (List# 12270-01) to the pole before attaching the infuser(s) to the tandem carrier.

Make sure tandem carrier clamp is attached firmly to the pole.

Make sure infusers are firmly attached to the tandem carrier.

This section details the Plum A+ instrument setup procedures.

SYSTEM SELF-TESTS

The infuser performs a suite of System Self-Tests when power is applied to confirm readiness for use.

Failure during the Self-Tests is reported as a Malfunction Condition.

CAUTION: DO NOT PLACE THE PLUM A+ IN SERVICE IF IT FAILS THE SYSTEM SELF-TESTS.

Connect the AC power (mains) cord to an AC power receptacle, then confirm that the Charging/Line indicator illuminates (above the [ON/OFF] key on the front panel).

A systematic self-testing of the processing, delivery, and safety systems is performed whenever the Plum A+ is turned on, to verify readiness for operation.

NOTE: If the quality of earth grounding source is in doubt, use battery power.

Press the [ON/OFF] key to turn the power on. Check the screen display and listen for a beep to indicate that the audio is working. Wait for the self-tests to complete. If successful, put a fully primed macro cassette into the cassette door and close the door. See *Loading the Cassette in Section 3* for details of correct procedure.

When the Charging/Line indicator is off and the battery symbol on the display is flashing, this indicates that the Plum A+ is operating on low battery power and should be recharged.

CAUTION: DO NOT OPERATE THE PLUM A+ ON PATIENTS WITH THE BATTERY REMOVED. USE OF A PROPERLY MAINTAINED AND CHARGED BATTERY HELPS CONFIRM PROPER OPERATION.

To confirm that the battery is fully charged, connect the Plum A+ to AC (mains) power for a minimum of six hours while in the OFF mode.

If an alarm occurs during the power on self-test, identify the alarm message, then take corrective action, see *Section 7, Alarms and Troubleshooting*.

Turn infuser OFF, then back ON. If the self-test alarm recurs, remove the infuser from service and contact the local Hospira representative.

DATA RETENTION

Delivery program settings and programming option selections are retained in non-volatile memory. If the Plum A+ has been turned off for longer than four hours, all delivery settings are cleared and programming option selections are restored to their default selections for next use.

4.2 Power On

- 1) Press **ON/OFF** to turn on the Plum A+ and you will see the System Self-Tests screen.

CAUTION: THE INFUSER MUST BE INITIALLY STARTED ON AC POWER, OTHERWISE THE DATAPORT MAY NOT OPERATE PROPERLY.

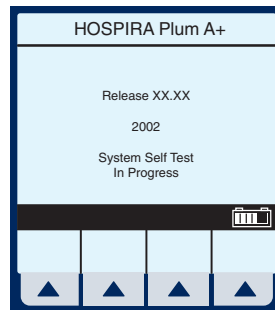

After self-testing successfully completes, the display will proceed to the next screen.

****SCREENS SHOWN IN THIS MANUAL ARE EXAMPLES ONLY AND DON'T NECESSARILY REFLECT ACTUAL CLINICAL PRACTICE****

Programming the infuser may begin during the cassette check phase of the start-up testing.

NOTE: If battery is missing or defective, a “Battery not installed” message with a “Continue without battery” prompt will appear (AC power only).

CAUTION: DO NOT OPERATE THE PLUM A+ ON PATIENTS WITH THE BATTERY REMOVED. USE OF A PROPERLY MAINTAINED AND CHARGED BATTERY HELPS CONFIRM PROPER OPERATION.

- 2) **To set up the Plum A+, insert selected PlumSet and close cassette holder door lever.**

NOTE: If cassette is already inserted, this screen is skipped.

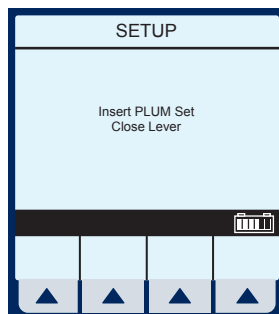

Example of Clear Settings Screen

- 3) **The on-screen message “Clear Settings?” may appear. Select ▲ [YES] to clear all settings.**

Clear ALL settings when changing patients or multiple programming parameters.

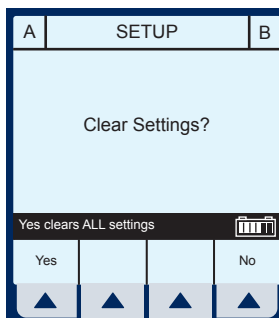

NOTE: This clears all delivery parameters, such as Rate and VTBI on both lines, as well as setting items, such as the KVO and Nurse Callback options, to their default values.

NOTE: If no settings currently exist or all settings are zero, this screen will be bypassed.

4.3 Simple Delivery

Example of Main Delivery screen (with cleared settings).

SCREENS SHOWN IN THIS MANUAL ARE EXAMPLES ONLY AND DON'T NECESSARILY REFLECT ACTUAL CLINICAL PRACTICE

A	STOPPED	STOPPED	B
0	Rate mL/hr	0	
0	Vol Inf mL	0	
Back Prime	A	B	Options/ Vol Inf
▲	▲	▲	▲

NOTE: For clarity, whole number font sizes will appear larger than partial number font sizes (numbers on the right-side of the comma).

- 1) To program delivery rate, select ▲ [A].
- 2) To enter delivery rate, use numeric keypad.
- 3) Use ▼ key to move down to the VTBI field.

A	PROGRAM		
Rate	0	mL/hr	
VTBI	0	mL	
Duration	00:00	hr : min	
Enter Value using keypad			
Program Options		Therapy	Cancel/ Back
▲	▲	▲	▲

4) **To enter VTBI amount, use keypad.**

NOTE: While the VTBI is being entered, the duration is automatically computed. If the computed value is greater than 99:59, dashes (- -) appear in place of hours.

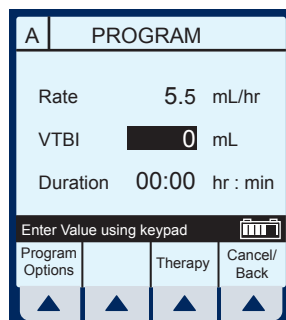

5) **Use ▼ key to move down to the Duration field.**

6) **Use the keypad to change the hours part of the Duration if desired.**

NOTE: When all parameters are displayed, changing any one parameter will result in other parameters automatically being computed. To understand the Automatic Calculation feature, see *Section 6.8, Examples of Automatic Calculation*.

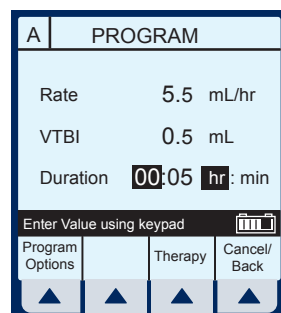

7) **Use ▼ to move from hours to minutes.**

NOTE: The maximum hours allowed is 99 and the maximum minutes is 59.

8) **Use keypad to change minutes.**

CAUTION: VERIFY ALL VALUES BEFORE STARTING INFUSION.

- 9) Press **START** to begin infusion.

Example of Main Delivery Screen just after being programmed and started.

NOTE: The Line A Fluid Flow Indicator also will flash to indicate pumping.

A	PUMPING	STOPPED	B
5.5	Rate mL/hr	0	
0.1	Vol Inf mL	0	
			
	A	B	Options/ Vol Inf
▲	▲	▲	▲

4.4 Titration

- 1) **Select Line ▲ [A] (or ▲ [B]) at the Main Delivery Screen.**

A	PUMPING	PUMPING	B
25	Rate mL/hr	50	
41	Vol Inf mL	20	
	A	B	Options/ Vol Inf
▲	▲	▲	▲

- 2) **Enter the Rate using the keypad.**

NOTE: When Rate is changed, the duration is automatically recomputed using the current VTBI. To understand the Automatic Calculation feature, see *Section 6.8, Examples of Automatic Calculation*.

A	PROGRAM		
Rate	<input type="text" value="15"/>	mL/hr	
VTBI	50	mL	
Duration	03:20	hr : min	
Enter Value using keypad			
Program Options		Therapy	Cancel/ Back
▲	▲	▲	▲

CAUTION: VERIFY ALL VALUES BEFORE STARTING INFUSION.

- 3) **After any change, press **START** to initiate new Rate and return to the Main Delivery Screen.**

NOTE: Volume Infused is an incrementing value which is cleared in ▲ [OPTIONS/VOL INF].

A	PUMPING	PUMPING	B
15	Rate mL/hr	50	
41.6	Vol Inf mL	25	
	A	B	Options/ Vol Inf
▲	▲	▲	▲

The following 3 screens are examples of changed values.

Example of changed rate.

- 4) From the Main Delivery Screen, select ▲ [A].
- 5) Use keypad to change the Rate value.

NOTE: The display time is only accurate to \pm one minute. As shown in this example, the delivery shows 3 hours and 20 minutes (not 3 minutes and 20 seconds).

NOTE: [START] accepts the change. Delivery is changed to the new Rate and Duration and display returns to Main Delivery Screen.

A	PROGRAM		
Rate	15	mL/hr	
VTBI	50	mL	
Duration	03:20	hr : min	
Enter Value using keypad 			
Program Options		Therapy	Cancel/Back
▲	▲	▲	▲

Example of Changed VTBI value.

- 6) Use ▼ key to highlight the VTBI field.
- 7) Use the keypad to change the VTBI value.

A	PROGRAM		
Rate	15	mL/hr	
VTBI	100	mL	
Duration	06:40	hr : min	
Enter Value using keypad 			
Program Options		Therapy	Cancel/Back
▲	▲	▲	▲

NOTE: When the VTBI is changed, the Duration is recomputed with respect to the current Rate. To understand the Automatic Calculation feature, see Section 6.8, Examples of Automatic Calculation.

NOTE: [START] accepts the change. Delivery is changed to the new VTBI and Duration and display returns to Main Delivery Screen.

Example of changed Duration field.

- 8) Use ▼ to highlight the Duration field, then use the keypad to change its value.

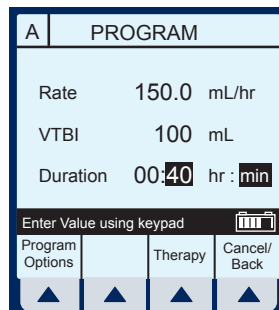

NOTE: When Duration is changed, Rate is automatically recomputed using the current VTBI value. To understand the Automatic Calculation feature, see *Section 6.8, Examples of Automatic Calculation*.

NOTE: [START] accepts the change. Delivery is changed to the new Duration and Rate and display returns to Main Delivery Screen.

CAUTION: VERIFY ALL VALUES BEFORE STARTING INFUSION.

4.5 Piggyback Delivery

PIGGYBACK DELIVERY - Infusion will stop Line A and infuse Line B until VTBI completes. Line A will automatically restart.

- 1) **With Line A pumping, to program a Piggyback delivery, select ▲ [B].**

A	PUMPING	STOPPED	B
5.5	Rate mL/hr	0	
20	Vol Inf mL	0	
▲	A	B	Options/ Vol Inf

The Delivery Mode field is highlighted.

NOTE: If an entry was previously programmed, Rate is highlighted. If no previous entries, Mode is highlighted.

- 2) **If field reads “Concurrent”, select ▲ [CHANGE MODE] to switch to “Piggyback”.**

PROGRAM			B
Mode	Piggyback		
Rate	0	mL/hr	
VTBI	0	mL	
Duration	00:00	hr : min	
Change using Change Mode			
Program Options	Change Mode	Therapy	Cancel/ Back
▲	▲	▲	▲

- 3) Select ▼ to highlight the Rate field.
- 4) To enter delivery rate, use numeric keypad.
- 5) Use ▼ key to move down to the VTBI field.

PROGRAM		B
Mode	Piggyback	
Rate	200	mL/hr
VTBI	0	mL
Duration	00:00	hr : min
Enter value using keypad 		
Program Options		Therapy Cancel/Back
▲	▲	▲ ▲

- 6) To enter VTBI amount, use keypad.

NOTE: While the VTBI is being entered, the duration is automatically computed. If the computed value is greater than 99:59, dashes (- -) appear in place of hours. To understand the Automatic Calculation feature, see *Section 6.8, Examples of Automatic Calculation*.

PROGRAM		B
Mode	Piggyback	
Rate	200	mL/hr
VTBI	100	mL
Duration	00:30	hr : min
Enter value using keypad 		
Program Options		Therapy Cancel/Back
▲	▲	▲ ▲

- 7) Use ▼ key to move down to the Duration field.

(Optional) Use keypad to change duration.

When all parameters are displayed, changing any one parameter will result in other parameters automatically being computed.

PROGRAM		B
Mode	Piggyback	
Rate	133	mL/hr
VTBI	100	mL
Duration	00:45	hr : min
Enter value using keypad 		
Program Options		Therapy Cancel/Back
▲	▲	▲ ▲

CAUTION: VERIFY ALL VALUES BEFORE STARTING INFUSION.

8) Press **START** to begin infusion.

NOTE: If Line A has a Delay Start remaining, a message will appear warning of a possible non-delivery (see Section 6.4).

9) Select **▲ [YES]** to continue.

Example of Main Delivery Screen just after being programmed and started.

A	DELAYED	PUMPING	B
5.5		Rate mL/hr	133
20		Vol Inf mL	0.1
	A	B	Options/ Vol Inf
▲	▲	▲	▲

4.6 Concurrent Delivery

CONCURRENT DELIVERY -
Simultaneous delivery of two fluids at independent flow rates.

CAUTION: CONSULT DRUG LABELING TO CONFIRM DRUG COMPATIBILITY, CONCENTRATION, DELIVERY RATES, AND VOLUME ARE ALL SUITABLE FOR CONCURRENT AND PIGGYBACK DELIVERY MODES. SEE SECTION 1 FOR INFORMATION ON CONCURRENT FLOW, SEE SECTION 9 FOR DELIVERY RATE RANGES.

A	PUMPING	STOPPED	B
5.5	Rate mL/hr		0
0.1	Vol Inf mL		0
	A	B	Options/ Vol Inf
▲	▲	▲	▲

NOTE: In Concurrent mode with certain alarm conditions, one line may stop while the other line may continue to deliver.

- 1) **With pumping started on line A, to program a Concurrent delivery rate, select ▲ [B].**

The Delivery Mode field is highlighted.

NOTE: If an entry was previously programmed, Rate is highlighted. If no previous entries, Mode is highlighted.

If field reads “Piggyback”, select ▲ [CHANGE MODE] to switch to “Concurrent”.

PROGRAM		B
Mode	Piggyback	
Rate	0 mL/hr	
VTBI	0 mL	
Duration	00:00 hr : min	
Change using Change Mode		
Program Options	Change Mode	Therapy
Cancel/Back		
▲	▲	▲

Verify change to “Concurrent” mode.

- 2) **Use ▼ to highlight Rate field.**

PROGRAM		B
Mode	Concurrent	
Rate	0 mL/hr	
VTBI	0 mL	
Duration	00:00 hr : min	
Change using Change Mode		
Program Options	Change Mode	Therapy
Cancel/Back		
▲	▲	▲

- 3) **To enter delivery rate, use numeric keypad.**

NOTE: When Rate for Line A plus Rate for Line B is greater than valid rate ranges, a “Concurrency violation” message will explain why second line did not start. See *Delivery Rate Range in Section 9* for valid delivery rate ranges.

PROGRAM		B
Mode	Concurrent	
Rate	10 mL/hr	
VTBI	0 mL	
Duration	00:00 hr : min	
Enter value using keypad		
Program Options	Therapy	Cancel/Back
▲	▲	▲

NOTE: “Concurrency violation” may not be displayed if unit is displaying “VTBI Complete”. The device will not start and an invalid keypress sound will occur when [START] is pressed.

- 4) Use ▼ key to move down to the VTBI field.
- 5) To enter VTBI amount, use keypad.

NOTE: While the VTBI is being entered, the Duration is automatically computed. While the computed value is greater than 99:59, dashes (- -) appear in place of hours. To understand the Automatic Calculation feature, see *Section 6.8, Examples of Automatic Calculation.*

PROGRAM		B	
Mode	Concurrent		
Rate	10	mL/hr	
VTBI	100	mL	
Duration	10:00	hr	: min
Enter value using keypad			
Program Options		Therapy	Cancel/Back
▲	▲	▲	▲

- 6) Use ▼ key to move down to the Duration field.

(Optional) Enter values for hours and minutes.

NOTE: When Duration is entered, Rate is automatically computed.

CAUTION: VERIFY ALL VALUES BEFORE STARTING INFUSION.

- 7) Press (START) to begin infusion and return to the Main Delivery screen.

Example of a concurrent delivery.

A	PUMPING	PUMPING	B
5.5	Rate mL/hr	10	
20.4	Vol Inf mL	1	
	A	B	Options/ Vol Inf
▲	▲	▲	▲

4.7 Stop and Start with Only 1 Line Pumping

- 1) Press **START** at the Main Delivery Screen.

NOTE: If ▲ [A] (or ▲ [B]) is selected prior to [STOP], the display will show the programming screen. Select ▲ [CANCEL/BACK] to return to the Main Delivery screen.

A	PUMPING	STOPPED	B
100	Rate mL/hr	0	
8.5	Vol Inf mL	0	
	A	B	Options/ Vol Inf
▲	▲	▲	▲

Example of stopped delivery.

- 2) To resume infusion, press **START**.

Or, to discontinue infusion, press **ON/OFF**.

A	STOPPED	STOPPED	B
100	Rate mL/hr	0	
8.5	Vol Inf mL	0	
Back Prime	A	B	Options/ Vol Inf
▲	▲	▲	▲

- 3) Clamp secondary tubing if connected.
- 4) Close all slide or CAIR clamps.
- 5) Open cassette door, remove set and close door.

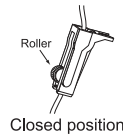
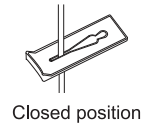

4.8 Stop and Start with Both Lines Pumping

- 1) Press **STOP** at the Main Delivery screen.

A	PUMPING	PUMPING	B
25	Rate mL/hr	50	
3	Vol Inf mL	20.4	
▲	A	B	Options/ Vol Inf
▲	▲	▲	▲

- 2) Select ▲ **[STOP A]**,
▲ **[STOP B]**, or
▲ **[STOP ALL]**.

NOTE: If ▲ **[A]** (or ▲ **[B]**) is selected prior to **[STOP]**, the display will show the programming screen. Select ▲ **[CANCEL/BACK]** to return to the Main Delivery screen.

A	PUMPING	PUMPING	B
25	Rate mL/hr	50	
3	Vol Inf mL	20.4	
Choose line(s) to stop:			
Stop All	Stop A	Stop B	Cancel
▲	▲	▲	▲

Example of stopped infusion.

NOTE: This is an example using ▲ [STOP ALL].

CAUTION: VERIFY ALL VALUES BEFORE STARTING INFUSION.

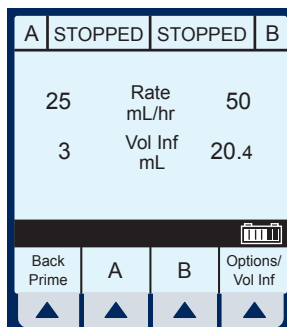

3) To resume infusion, press (START).

4) Select ▲ [START A], ▲ [START B], or ▲ [START ALL]. Or, to discontinue infusion, press (ON/OFF).

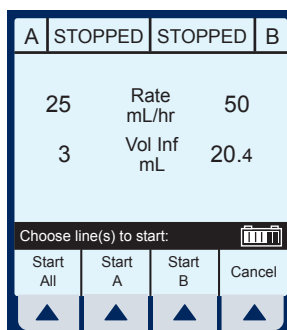

5) Clamp secondary tubing if connected.

6) Close all slide or CAIR clamps.

7) Open cassette door, remove set and close door.

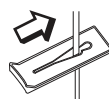

To close slide clamp

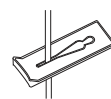

Closed position

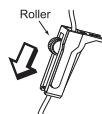

To close CAIR (roller) clamp

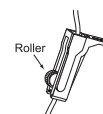

Closed position

4.9 Backpriming

BACKPRIMING - Removal of air or fluid from the proximal line and cassette airtrap.

- 1) To initiate a backprime, select ▲ [BACK PRIME].

NOTE: Backpriming is available only when all delivery is stopped. Secondary container is necessary to receive the air.

A	STOPPED	STOPPED	B
5.5	Rate mL/hr	0	
8.9	Vol Inf mL	0	
Back Prime	A	B	Options/ Vol Inf
▲	▲	▲	▲

- 2) Select and hold ▲ [BACK PRIME] until fluid pumped from line A to line B has expelled the air from cassette air trap into Secondary container.

NOTE: Fluid flow is at maximum rate possible.

A	BACKPRIMING	B
5.5	Rate mL/hr	0
8.9	Vol Inf mL	0
Back Prime	A	B
▲	▲	▲

Release Backprime to Stop

- 3) Upon release of ▲ [BACK PRIME], the cassette test is performed to confirm readiness for pumping. Pressing (START) will resume programmed delivery.

4.10 Clearing Program Settings

- 1) Press **STOP** at the Main Delivery Screen.

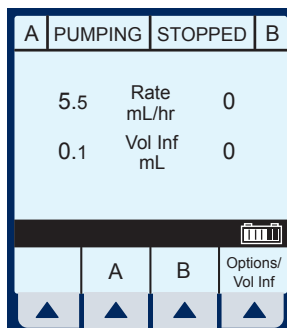

- 2) Select Line A (or B if active) from the stopped Main Delivery Screen.

- 3) Select ▲ [CLEAR PROGRAM].

NOTE: Use ▲ [CLEAR PROGRAM] when changing ONLY Line A or B.

NOTE: If Line A or B is programmed with Dose Calculation, Rate, VTBI and Duration will not display values. The values to be cleared may be viewed in applicable programming screen under ▲ [DRUG LIST].

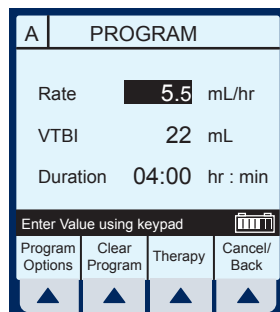

4) **Select ▲ [YES].**

Clear ALL settings when changing patients or multiple programming parameters.

Use ▲ [CLEAR PROGRAM] when changing ONLY Line A or B.

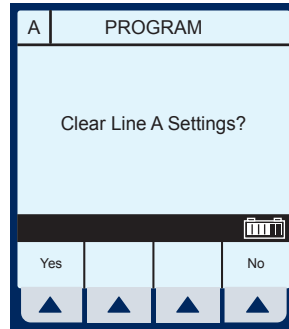

Example screen of “Cleared Program”.

5) **Select ▲ [CANCEL/BACK] to return to the Main Delivery screen or program new settings.**

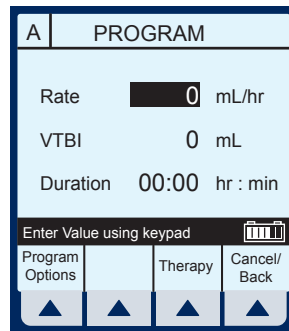

4.11 Clearing Program Settings When Both Lines Are Programmed

NOTE: Clear ALL settings when changing patient or multiple programming parameters.

- 1) Press **STOP** at the Main Delivery Screen.

A	PUMPING	PUMPING	B
25	Rate mL/hr	50	
3	Vol Inf mL	20.4	
	A	B	Options/ Vol Inf

- 2) Select **▲ [STOP A]**, **▲ [STOP B]**, or **▲ [STOP ALL]**.
In this example, both lines are being cleared, so **▲ [STOP ALL]** is selected.

A	PUMPING	PUMPING	B
25	Rate mL/hr	50	
3	Vol Inf mL	20.4	
Choose line(s) to stop:			
Stop All	Stop A	Stop B	Cancel

3) Select a line to clear.

A	STOPPED	STOPPED	B
25	Rate mL/hr	50	
3	Vol Inf mL	20.4	
Back Prime	A	B	Options/ Vol Inf
▲	▲	▲	▲

4) Select ▲ [YES].

5) Press ▲ [CANCEL/BACK] to return to the Main Delivery Screen.

6) Select the other line to be cleared.

7) Select ▲ [YES].

8) Press ▲ [CANCEL/BACK] to return to the Main Delivery Screen.

NOTE: Refer to *Section Power On*, for instructions on clearing ALL settings.

A	PROGRAM		
Clear Line A Settings?			
Yes			No
▲	▲	▲	▲

A	PROGRAM		
Rate	<input type="text" value="0"/>	mL/hr	
VTBI	<input type="text" value="0"/>	mL	
Duration	<input type="text" value="00:00"/>	hr : min	
Enter Value using keypad			
Program Options		Therapy	Cancel/ Back
▲	▲	▲	▲

5)

Therapies

Dose Calculation	<i>Allows programming Dose Rates in alternative units of measure. Dose Calculation can be used in Simple Delivery, Loading Dose, and Multistep.</i>
Loading Dose	<i>Allows programming of an initial infusion rate for a specific volume, followed automatically by a maintenance rate from the same container (for example, a fluid challenge). If Dose Calc is used, the Loading Dose and Maintenance Dose are in the same unit of measure, over the same period of time (mcg/min), from the same container.</i>
Multistep	<i>Allows a sequential program to deliver up to 10 steps; fluid volumes and delivery rates may be programmed for each step. The program may be entered based on Rate and Volume or Volume and Time. If Dose Calc is used, the delivery steps are in the same unit of measure, over the same period of time, from the same container.</i>

NOTE: During programming, user must identify drug with softkey drug list prior to setting program parameters.

Use drug manufacturer recommendations for IV administration when using the Plum A+ infuser.

5.1 Dose Calc (mcg/kg/min on A)

DOSE CALCULATION - Allows programming Dose Rates in alternative units of measure. Dose Calculation can be used in Simple Delivery, Loading Dose, and Multistep.

Clear ALL values when changing patients or multiple programming parameters.

Use ▲ [CLEAR PROGRAM] when changing ONLY Line A or B.

- 1) Select ▲ [A] at the Main Delivery screen.

SCREENS SHOWN IN THIS MANUAL ARE EXAMPLES ONLY AND DON'T NECESSARILY REFLECT ACTUAL CLINICAL PRACTICE

A	STOPPED	STOPPED	B
0	Rate mL/hr	0	
0	Vol Inf mL	0	
Back Prime	A	B	Options/ Vol Inf
▲	▲	▲	▲

The Line A Programming screen appears.

- 2) Select ▲ [THERAPY] for Dose Calculation programming.

A	PROGRAM		
Rate	<input type="text" value="0"/>	mL/hr	
VTBI	<input type="text" value="0"/>	mL	
Duration	<input type="text" value="00:00"/>	hr : min	
Enter Value using keypad			
Program Options		Therapy	Cancel/ Back
▲	▲	▲	▲

The Drug List screen appears.

NOTE: Default entry is “No Drug Selected”. This selection may be used later to remove a name from the display.

- 3) Use ▲▼ to highlight a drug name.

To move quickly through the drug list, select ▲ [PAGE DOWN] (or ▲ [PAGE UP]). Then use ▲▼ to highlight choice.

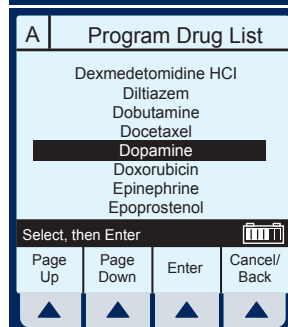
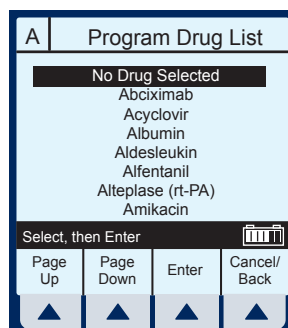

- 4) Select ▲ [ENTER] to indicate selection and advance to the Program Selection screen.

The Program Selection screen for Line A appears.

- 5) Select ▲ [CHOOSE] to select Dose Calculation and continue.

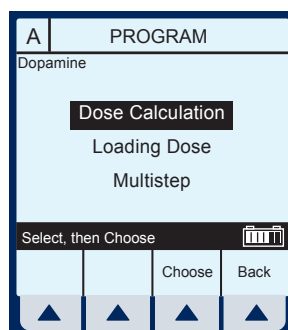

The Program Dose Calc screen appears.

NOTE: Cursor defaults to package insert recommended dose units associated with the selected drug.

- 6) **Select ▲ [CHOOSE] to continue. Or, use ▲▼ to change the units to use in the delivery.**

The Container Concentration Selection screen appears whenever the selected Dose Units are gram-based (for example, grams, mg, mcg, or ng) otherwise this screen is skipped.

NOTE: Cursor defaults to package insert recommended concentration units associated with the selected drug.

- 7) **Select ▲ [CHOOSE] to continue. Or, use ▲▼ to change the Container Concentration units to use in the delivery.**

The next page of the Program Dose Calc screen allows entry of delivery program parameters.

- 8) Use keypad to enter values. Once each value is entered, use ▼ to highlight the next programming field.

A		Program Dose Calc	
Dopamine			
Conc	400 mg	250 mL	
Weight	70 kg		
Dose		0 mcg/kg/min	
VTBI		0 mL	
Duration	00: 00	hr : min	
Rate		0 mL/hr	
Enter value using keypad 			
Program Options			Cancel/Back
▲	▲	▲	▲

NOTE: The Concentration elements and weight value must be entered before the [SELECT] keys allow access to remaining fields.

- 9) Continue to enter values using the keypad, and advancing to the next field using ▼.

NOTE: As the Dose value is entered, the Rate is automatically calculated. To understand the Automatic Calculation feature, see Section 6, Examples of Automatic Calculation.

A		Program Dose Calc	
Dopamine			
Conc	400 mg	250 mL	
Weight	70 kg		
Dose	10	mcg/kg/min	
VTBI		0 mL	
Duration	00: 00	hr : min	
Rate		26.3 mL/hr	
Enter value using keypad 			
Program Options			Cancel/Back
▲	▲	▲	▲

10) Use ▼ to scroll down to the VTBI field.

11) Enter a value for VTBI using the keypad.

NOTE: As the VTBI value is entered or changes, Duration is automatically updated.

NOTE: At this point, programming is complete unless ▲ [PROGRAM OPTIONS] are desired. See Section 6, *Additional Features* for more information.

A	Program Dose Calc	
Dopamine		
Conc	400 mg	250 mL
Weight	70 kg	
Dose	10 mcg/kg/min	
VTBI	250 mL	
Duration	09:30 hr : min	
Rate	26.3 mL/hr	
Enter value using keypad <input type="text"/>		
Program Options		Cancel/Back
▲	▲	▲

12) Press **START** to begin program.

The Program Confirmation screen appears for all units of measure except mL/hr.

CAUTION: VERIFY ALL VALUES BEFORE SELECTING ▲ [YES] AND STARTING INFUSION.

NOTE: The Concentration drug amount or Diluent volume cannot be changed while a delivery is in progress.

A	Program Dose Calc	
Delivery will be:		
Dose	10 mcg/kg/min	
Drug	Dopamine	
Conc	400 mg	250 mL
Weight	70 kg	
Confirm Program?		
<input type="text"/>		
Yes		No
▲	▲	▲

The Main Delivery screen displays the information just entered.

NOTE: The therapy type, drug, dose rate, and dose units are displayed.

A	PUMPING	STOPPED	B
Dopamine			
Dose Calculation			
26.3	Rate mL/hr	0	
0	Vol Inf mL	0	
10 mcg/kg/min			
	A	B	Options/ Vol Inf

5.2 Dose Calc (mg/min on B)

DOSE CALCULATION - Allows programming Dose Rates in alternative units of measure. Dose Calculation can be used in Simple Delivery, Loading Dose, and Multistep.

Clear ALL values when changing patients or multiple programming parameters.

Use ▲ [CLEAR PROGRAM] when changing ONLY Line A or B.

- 1) **Select ▲ [B] at the Main Delivery screen.**

A	PUMPING	STOPPED	B
Dopamine Dose Calculation			
26.3	Rate mL/hr	0	
0	Vol Inf mL	0	
10	mcg/kg/min		
	A	B	Options/ Vol Inf
▲	▲	▲	▲

The Line B Programming screen appears.

- 2) **Select ▲ [THERAPY].**

PROGRAM		B
Mode	Piggyback	
Rate	0	mL/hr
VTBI	0	mL
Duration	00:00	hr : min
Change using Change Mode		
Program Options	Change Mode	Therapy
Cancel/ Back		
▲	▲	▲

The Drug List screen appears.

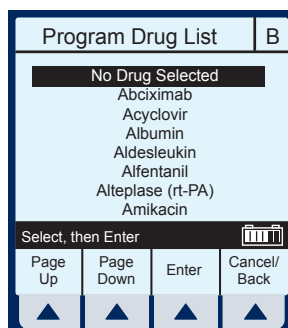

- 3) Use ▲▼ to highlight drug name.

To move quickly through the drug list, select ▲ [PAGE DOWN] (or ▲ [PAGE UP]). Then use ▲▼ to highlight choice.

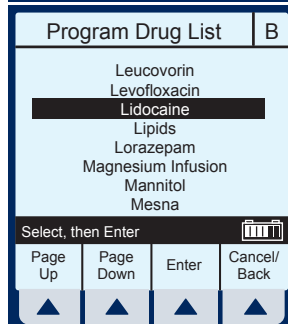

- 4) Select ▲ [ENTER] to indicate selection and advance to the Select Therapy screen.

The Program Select screen for Line B appears.

- 5) Select ▲ [CHOOSE] to continue.

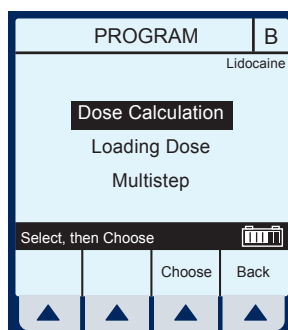

The Program Dose Calc screen appears.

NOTE: Cursor defaults to manufacturer package insert recommended dose units associated with the selected drug.

- 6) Select ▲ [CHOOSE] to continue. Or, use ▲▼ to change the units to use in the delivery.

Program Dose Calc		B
Lidocaine		
mL/hr	grams/hr	
mcg/kg/min	ng/kg/min	
mcg/kg/hr	units/kg/hr	
mcg/min	units/min	
mcg/hr	units/hr	
mg/kg/hr	mUn/min	
mg/min	mEq/hr	
mg/hr		
Select, then Choose 		
	Choose	Back
▲	▲	▲





The Container Concentration Selection screen appears whenever the selected Dose Units are gram-based (for example, grams, mg, mcg, or ng) otherwise this screen is skipped.

NOTE: Cursor defaults to manufacturer package insert recommended concentration units associated with the selected drug.





- 7) Select ▲ [CHOOSE] to continue. Or, use ▲▼ to change the Container Concentration units to use in the delivery.

Program Dose Calc		B
Lidocaine		
Drug Conc in Container		
mcg		
mg		
grams		
Select, then Choose 		
	Choose	Back
▲	▲	▲

The next page of the Program Dose Calc screen allows entry of delivery program parameters.

Program Dose Calc		B
		Lidocaine
Conc	0 grams 0 mL	
Mode	Piggyback	
Dose	0 mg/min	
VTBI	0 mL	
Duration	00:00 hr: min	
Rate	0 mL/hr	
Enter value using keypad 		
Program Options		Cancel/Back
		





- 8) Use keypad to enter values. Once entered, use ▼ to highlight the next field.
- 9) To override the Piggyback Delivery Mode default, scroll down to Mode using ▼, then select ▲ [\[CHANGE MODE\]](#).

Program Dose Calc		B
		Lidocaine
Conc	2 grams 500 mL	
Mode	Piggyback	
Dose	0 mg/min	
VTBI	0 mL	
Duration	00:00 hr: min	
Rate	0 mL/hr	
Enter value using keypad 		
Program Options	Change Mode	Cancel/Back
		

NOTE: Delivery Mode option is available on Line B and its default is Piggyback. The weight field is independent of Line A unless Line A selected drug is weight-based. In that scenario, the Line A weight information applies to Line B.

10) **Continue entering values using the keypad. Use ▼ to advance to the next field.**

NOTE: When entering the Rate, with a VTBI value entered, the Dose and Duration fields are automatically updated. To understand the Automatic Calculation feature, see *Section 6.8, Examples of Automatic Calculation*.

Program Dose Calc		B
		Lidocaine
Conc	2 grams	
	500 mL	
Mode	Concurrent	
Dose	2 mg/min	
VTBI	500 mL	
Duration	16 : 40	hr : min
Rate	30	mL/hr
Enter value using keypad 		
Program Options		Cancel/Back
		

NOTE: The Duration field temporarily changes to dashes when the computed value is larger than what can be displayed.

11) **(Optional) Continue entering the Rate value.**

NOTE: As Rate is entered, the Duration and Dose are automatically adjusted as individual numbers are entered.

NOTE: If the Duration value is changed, the Rate and Dose are automatically adjusted.

NOTE: At this point, programming is complete unless ▲ [Program Options] are desired. See *Section 6, Additional Features* for more information.

12) Press **(START)** to begin program.

The Program Confirmation screen appears for all units of measure except mL/hr.

CAUTION: VERIFY ALL VALUES BEFORE SELECTING ▲ [YES] AND STARTING INFUSION.

NOTE: The Concentration drug amount or Diluent volume cannot be changed while a delivery is in progress.

*Upon **(START)**, the Main Delivery screen shows delivery status for both A and B lines.*

NOTE: See *Delivery Rate Range in Section 9*. The ratio of concurrent rates has recommendations specified in *Section 1*.

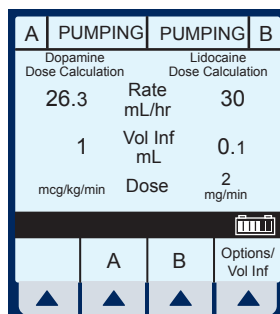
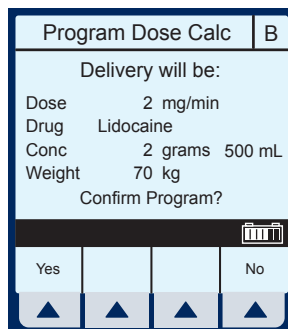

5.3 Loading Dose

LOADING DOSE - Allows programming of an initial infusion rate for a specific volume, followed automatically by a maintenance rate from the same container (for example, a fluid challenge). If Dose Calc is used, the Loading Dose and Maintenance Dose are in the same unit of measure, over the same period of time (mcg/min), from the same container.

Clear ALL values when changing patients or multiple programming parameters.

Use ▲ [CLEAR PROGRAM] when changing ONLY Line A or B.

- 1) **Select ▲ [A] (or ▲ [B]) at the Main Delivery screen.**

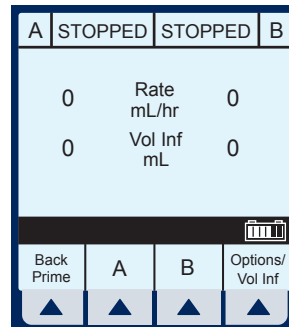

The selected Line (A or B) Programming screen appears.

NOTE: This example shows line A being programmed.

- 2) Select ▲ [THERAPY].

The Drug List screen appears.

NOTE: Default entry is “No Drug Selected”. This process will guide you through a “fluid challenge”, so “No Drug Selected” will be entered.

- 3) Select ▲ [ENTER] to indicate selection and advance to the Select Therapy screen.

The Select Therapy screen for Line A (or B) appears.

- 4) Use ▼ to scroll down to Loading Dose.
- 5) Select ▲ [CHOOSE] to continue.

A PROGRAM

Dose Calculation

Loading Dose

Multistep

Select, then Choose

Choose Back

The next page of the Program Loading Dose screen appears.

- 6) Select ▲ [CHOOSE] to continue. Or, use ▼ to change the units to use in the delivery.

A Program Loading Dose

mL/hr	grams/hr
mcg/kg/min	ng/kg/min
mcg/kg/hr	units/kg/hr
mcg/min	units/min
mcg/hr	units/hr
mg/kg/hr	mUn/min
mg/min	mEq/hr
mg/hr	

Select, then Choose

Choose Back

The Loading Dose Programming screen appears.

- 7) The default field is Rate. Since a “fluid Challenge” is being performed in this example, press ▼ to advance to the VTBI field.

A Program Loading Dose

	Rate	VTBI	Duration
	mL/hr	mL	hr : min
1	0	0	00 : 00
2	0	0	00 : 00





Enter value using keypad

Program Options Cancel/Back

8) Enter value using keypad.

A Program Loading Dose			
	Rate mL/hr	VTBI mL	Duration hr : min
1	0	250	00 : 00
2	0	0	00 : 00

Enter value using keypad 





Program Options			Cancel/Back
			

9) Use ▼ to highlight the next field.

- 10) Enter Duration using keypad. The Rate value is automatically calculated. To understand the Automatic Calculation feature, see Section 6.8, *Examples of Automatic Calculation*

A Program Loading Dose			
	Rate mL/hr	VTBI mL	Duration hr : min
1	500	250	00 : 30
2	0	0	00 : 00





Enter value using keypad 

Program Options			Cancel/Back
			

- 11) After the values for loading dose (Step 1) are entered, use ▼ to highlight the maintenance dose (Step 2).

A Program Loading Dose			
	Rate mL/hr	VTBI mL	Duration hr : min
1	500	250	00 : 30
2	75	0	00 : 00

Enter value using keypad 

Program Options			Cancel/Back
			

NOTE: The Loading Dose therapy has two steps. The first is the loading dose followed by the maintenance dose. These words appear on the main screen as each step is delivered.

12) Enter the set of values for Step 2 of the program.

13) Select ▲ [PROGRAM OPTIONS] to select a Delayed Start or Standby.

NOTE: At this point, programming is complete unless ▲ [PROGRAM OPTIONS] are desired. See Section 6, Additional Features for more information.

NOTE: Nurse Callback enables an alarm when a change in the delivery on a line occurs such as completing Step 1 and starting Step 2. Or on line B, a piggyback delivery is completed and line A is starting its delivery.

A Program Loading Dose			
	Rate	VTBI	Duration
	mL/hr	mL	hr : min
1	500	250	00 : 30
2	75	750	10 : 00
Enter value using keypad			<input type="text"/>
Program Options			Cancel/Back
▲	▲	▲	▲

A Program Options			
Delay Start for 00:00 hr:min			
Callback		No	
Enter Value using keypad			<input type="text"/>
	Standby	Enter	Cancel/Back
▲	▲	▲	▲

14) Enter a delay time (less than or equal to 24 hours) using the keypad.

NOTE: Not available if a delivery is taking place on the line.

15) (Optional) Select Nurse Callback.

A Program Options			
Delay Start for 00:05 hr:min			
Callback		Yes	
Change using Yes/No			<input type="text"/>
	Yes/No	Enter	Cancel/Back
▲	▲	▲	▲

NOTE: Nurse Callback cannot be changed while a delivery is taking place on the line.

- 16) Select ▲ [ENTER] to accept the changes and return to the Program Loading Dose screen.

NOTE: ▲ [CANCEL/BACK] returns the fields to their original value and displays the previous screen.

CAUTION: VERIFY ALL VALUES BEFORE STARTING INFUSION.

- 17) Press (START) to begin program.

The Main Delivery Screen appears.

NOTE: The words “DELAYED” and “Loading Dose” appear in the upper-left corner. These indicate the options which have been selected.

A	DELAYED	STOPPED	B
Loading Dose			
500	Rate mL/hr	0	
0	Vol Inf mL	0	
			
	A	B	Options/ Vol Inf
▲	▲	▲	▲

After the programmed delay period has expired, the Plum A+ starts “PUMPING”. This is indicated where “DELAYED” previously was displayed.

A	PUMPING	STOPPED	B
Loading Dose			
500	Rate mL/hr	0	
0	Vol Inf mL	0	
			
	A	B	Options/ Vol Inf
▲	▲	▲	▲

After the Step 1 (loading dose) has completed, the Main Delivery screen changes to the second step (maintenance dose).

NOTE: A flashing “Callback Line A” message and the audio alarm indicate that Step 1 has completed.

A	PUMPING	STOPPED	B
Maintenance Dose			
75	Rate mL/hr	0	
250	Vol Inf mL	0	
N105 Callback Line A			
	A	B	Options/ Vol Inf
▲	▲	▲	▲

- 18) The user should acknowledge the Callback message and stop the audio alarm by pressing .

Upon completion of delivery, the screen shows a flashing “Line A VTBI complete” message and the audible alarm sounds.

NOTE: The KVO rate will change to the rate of 1 mL/hr or less depending on delivery rate and “PUMPING” mode changes to “KVO”. If Continue Rate option was selected, pumping continues at original rate.

A	KVO	STOPPED	B
Maintenance Dose			
1	Rate mL/hr	0	
1000	Vol Inf mL	0	
N161 Line A VTBI complete			
	A	B	Options/ Vol Inf
▲	▲	▲	▲

- 19) Press to stop alarm sound.

NOTE: Warning message continues to flash and audio alarm will return after a two minute period of silence, unless delivery is stopped or VTBI of last line is changed.

5.4 Multistep Programming

MULTISTEP - Allows a sequential program to deliver up to 10 steps; fluid volumes and delivery rates may be programmed for each step. The program may be entered based on Rate and Volume or Volume and Time. If Dose Calc is used, the delivery steps are in the same unit of measure, over the same period of time, from the same container.

Clear ALL values when changing patients or multiple programming parameters.

Use ▲ [CLEAR PROGRAM] when changing ONLY Line A or B.

- 1) **Select ▲ [A] at the Main Delivery screen.**

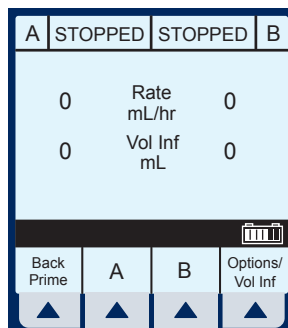

The Line A Programming screen appears.

- 2) Select ▲ [THERAPY].

A	PROGRAM		
Rate	0	mL/hr	
VTBI	0	mL	
Duration	00:00	hr : min	
Enter Value using keypad			
Program Options		Therapy	Cancel/Back
▲	▲	▲	▲

The Drug List Screen appears.

- 3) Use ▲▼ to highlight drug name.

To move quickly through the drug list, select ▲ [PAGE DOWN] (or ▲ [PAGE UP]). Then use ▲▼ to highlight choice.

A	Program Drug List		
No Drug Selected			
Abciximab			
Acyclovir			
Albumin			
Aldesleukin			
Alfentanil			
Alteplase (rt-PA)			
Amikacin			
Select, then Enter			
Page Up	Page Down	Enter	Cancel/Back
▲	▲	▲	▲

A	Program Drug List		
Ticar-clavulanate			
Tirofiban			
Tobramycin			
TPN			
Urokinase			
Vancomycin			
Vecuronium			
Verapamil			
Select, then Enter			
Page Up	Page Down	Enter	Cancel/Back
▲	▲	▲	▲

- 4) Select ▲ [ENTER] to indicate selection and advance to the Select Therapy screen.

The *Select Therapy* screen for Line A (or B) appears.

NOTE: This example shows line A being programmed.

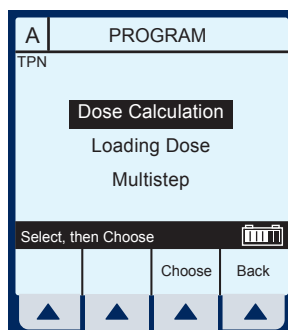

- 5) Use ▼ to scroll down to **Multistep**.
- 6) Select ▲ [CHOOSE] to continue.

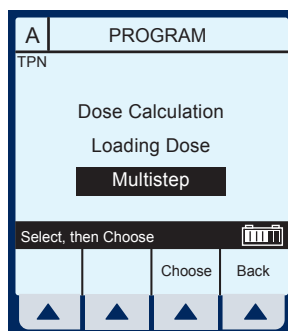

The *Program Multistep* screen appears.

NOTE: Cursor defaults to package insert recommended dose units associated with the selected drug.

- 7) Use ▲▼ key to highlight the units to use in the delivery.
- 8) Select ▲ [CHOOSE] to continue.

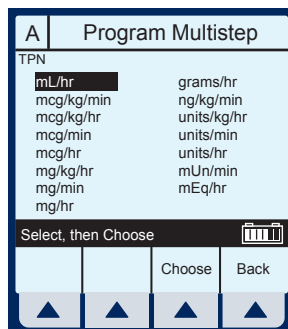

The Multistep Programming screen appears.

- 9) **Rate is the default field.
Enter value using keypad.**

A Program Multistep			
TPN			
	Rate mL/hr	VTBI mL	Duration hr : min
1	50	0	00: 00
2	0	0	00: 00
3	0	0	00: 00
4	0	0	00: 00

Enter value using keypad

Program Options		More Steps	Cancel/ Back
▲	▲	▲	▲

- 10) **Use ▼ to highlight the
Duration or VTBI field.**

NOTE: The VTBI value is automatically computed when the Duration value is entered. If VTBI is entered, the Duration value is automatically computed.

A Program Multistep			
TPN			
	Rate mL/hr	VTBI mL	Duration hr : min
1	50	50	01: 00
2	0	0	00: 00
3	0	0	00: 00
4	0	0	00: 00

Enter value using keypad

Program Options		More Steps	Cancel/ Back
▲	▲	▲	▲

- 11) **Use ▼ to drop down to
Step 2, Rate field.**

- 12) **Enter the set of values for
Step 2 of the program.
Continue process for
each additional Step.**

A Program Multistep			
TPN			
	Rate mL/hr	VTBI mL	Duration hr : min
1	50	50	01: 00
2	100	0	00: 00
3	0	0	00: 00
4	0	0	00: 00

Enter value using keypad

Program Options		More Steps	Cancel/ Back
▲	▲	▲	▲

NOTE: When Step 4 is programmed, using the [SELECT] keys to advance will highlight another item on this screen.

- 13) **When Step 4 is programmed, select**
▲ [MORE STEPS] to
program up to 10 Steps.

A Program Multistep			
TPN			
	Rate mL/hr	VTB mL	Duration hr: min
1	50	50	01: 00
2	100	825	08: 15
3	75	75	01: 00
4	50	50	01: 00

Enter value using keypad

Program Options		More Steps	Cancel/Back
▲	▲	▲	▲

NOTE: Using the [SELECT] keys will not advance you to the additional steps.

- 14) **To set up Steps 5 through 10, enter values as performed for Steps 1 through 4.**

To see the previous steps, select ▲ [PREV STEPS].

NOTE: Confirmation screen will appear ONLY if using weight-based program.

A Program Multistep			
TPN			
	Rate mL/hr	VTBI mL	Duration hr: min
5	0	0	00: 00
6	0	0	00: 00
7	0	0	00: 00
8	0	0	00: 00
9	0	0	00: 00
10	0	0	00: 00

Enter value using keypad

Program Options		Prev Steps	Cancel/Back
▲	▲	▲	▲

CAUTION: VERIFY ALL VALUES BEFORE STARTING INFUSION.

- 15) **Press to begin program.**

The Main Delivery screen displays Step 1 in the upper-left corner.

NOTE: In units other than mL/hr, the Dose Rate and Units also will be displayed.

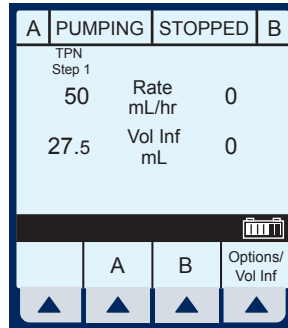

Example of Multistep Screen Pumping on Step 2.

- 16) To change a program parameter while pumping, select ▲ [A].

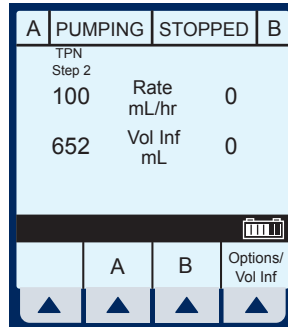

NOTE: The “*” in a Step number field indicates the step is delivering and “d” indicates each completed step.

- 17) Enter a value using the keypad.

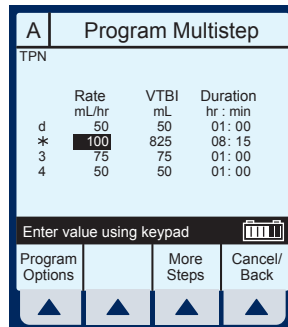

If Rate value is changed, the Duration will automatically change.





NOTE: Only the current delivering step and future steps can be changed.





CAUTION: VERIFY ALL VALUES BEFORE STARTING INFUSION.

NOTE: The Values are now updated on the Main Delivery Screen.

The infuser reverts to KVO when last Step completes.

The last step can be restarted by entering a new VTBI value.

A Program Multistep			
TPN			
	Rate mL/hr	VTBI mL	Duration hr : min
d	50	50	01 : 00
* *	125	825	06 : 36
3	75	75	01 : 00
4	50	50	01 : 00
Enter value using keypad 			
Program Options		More Steps	Cancel/Back
			

A	PUMPING	STOPPED	B
TPN			
Step 2			
125	Rate mL/hr	0	
658	Vol Inf mL	0	
			
	A	B	Options/ Vol Inf
			

NOTES

6) Additional Features

6.1 Simple Delivery Using Drug List

- 1) **Select Line ▲ [A] (or ▲ [B]) at the Main Delivery screen.**

SCREENS SHOWN IN THIS MANUAL ARE EXAMPLES ONLY AND DON'T NECESSARILY REFLECT ACTUAL CLINICAL PRACTICE

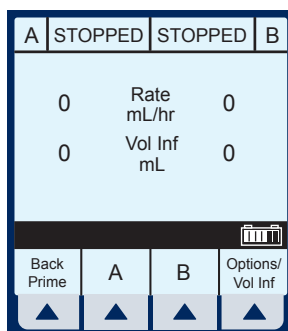

The Line A Programming screen appears.

- 2) **Select ▲ [PROGRAM OPTIONS].**

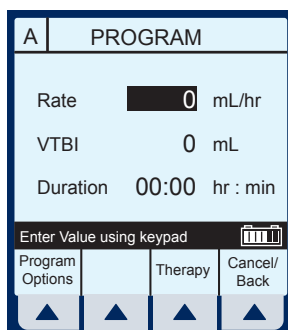

The default screen for Program Options appears.

- 3) **Select ▲ [DRUG LIST].**

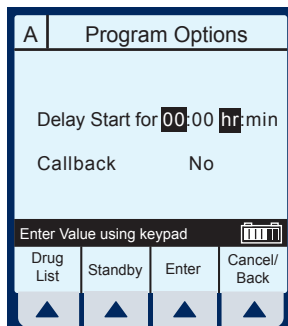

The Drug List screen appears, in mainly alphabetical order.

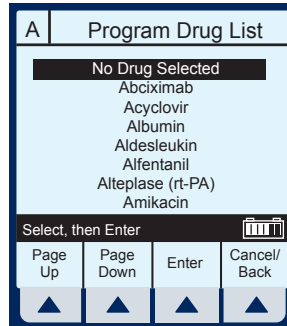

- 4) Use ▲▼ to highlight drug name.

To move quickly through the drug list, select ▲ [PAGE DOWN] (or ▲ [PAGE UP]). Then use ▲▼ to highlight choice.

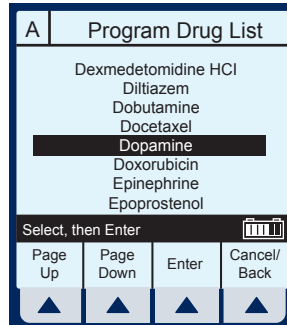

- 5) Select ▲ [ENTER] to indicate selection and return to the Program Options screen. Or, select ▲ [CANCEL/BACK] if no choice is acceptable.

Drug name is now visible in the upper-left corner.

- 6) Select ▲ [ENTER] or ▲ [CANCEL/BACK] to return to the Line Programming screen.

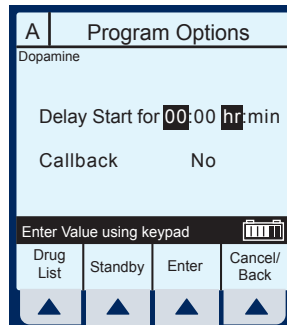



CAUTION: VERIFY ALL VALUES BEFORE STARTING INFUSION.

Notice the drug name remains in the upper-left corner.

- 7) Enter a Rate using the keypad.
- 8) Use ▼ to highlight the VTBI field and enter a value. The Duration is automatically calculated.
- 9) Press **START** to begin program and return to the Main Delivery screen.

Notice the drug name remains in the upper-left corner.

A	PROGRAM		
Dopamine			
Rate	5	mL/hr	
VTBI	250	mL	
Duration	50:00	hr : min	
Enter Value using keypad 			
Program Options		Therapy	Cancel/Back
▲	▲	▲	▲

A	PUMPING	STOPPED	B
Dopamine			
5	Rate mL/hr	0	
0.1	Vol Inf mL	0	
			
	A	B	Options/Vol Inf
▲	▲	▲	▲

6.2 Simple Delivery Using Delayed Start

- 1) **Before or after entering the simple delivery program, select**
▲ [PROGRAM OPTIONS].

NOTE: To program a Delayed Start using a Therapy (that is, Dose Calc) you must first select which line you want (A or B), next select ▲ [DRUG LIST], and then ▲ [PROGRAM OPTIONS]. If you program the Delayed Start first, it will be cleared upon entry into Program mode.

The Default screen for Program Options appears.

PROGRAM		B
Mode	Concurrent	
Rate	5 mL/hr	
VTBI	250 mL	
Duration	50:00 hr : min	
Change using Change Mode 		
Program Options	Change Mode	Therapy
		Cancel/Back
▲	▲	▲

Program Options		B
Delay Start for	00:00 hr:min	
Callback	No	
Enter Value using keypad 		
Drug List	Standby	Enter
		Cancel/Back
▲	▲	▲

- 2) Enter values for hours and/or minutes.
- 3) Select ▲ [ENTER] to confirm delayed start.

CAUTION: VERIFY ALL VALUES BEFORE STARTING INFUSION.

- 4) Press (START) to begin program.

Program Options		B
Delay Start for	01:00	hr:min
Callback	No	
Enter Value using keypad		
Drug List	Standby	Enter
Cancel/Back		
▲	▲	▲

Line B is delayed for the time entered.

NOTE: Delayed line drip indicator is solid, not flashing. It will begin flashing when actually pumping.

A	PUMPING	DELAYED	B
125	Rate	5.0	mL/hr
850	Vol Inf	0.0	mL
Enter value using keypad			
	A	B	Options/Vol Inf
▲	▲	▲	▲

6.3 Piggyback with Nurse Callback

- 1) After programming values for both lines, select ▲ [PROGRAM OPTIONS].

NOTE: To set a Nurse Callback, the infuser must be stopped. This function can be selected either before or after entering the Piggyback delivery program.

PROGRAM		B
Mode	Piggyback	
Rate	200	mL/hr
VTBI	100	mL
Duration	00:30	hr : min
Enter value using keypad		
Program Options	Therapy	Cancel/Back
▲	▲	▲

The default screen for Program Options appears.

- 2) Use ▼ to highlight “Callback” field and select ▲ [YES/NO], if necessary to obtain “Yes”, then select ▲ [ENTER].

Program Options		B
Delay Start for 00:00 hr:min		
Callback		Yes
Change using Yes/No 		
Drug List	Yes/No	Enter
Cancel/Back		
▲	▲	▲

NOTE: Callback default of Yes or No is a biomedical setting and must be configured as described in the Technical Service Manual.

CAUTION: VERIFY ALL VALUES BEFORE STARTING INFUSION.

- 3) Press (START) to begin program and return to Main Delivery screen.

PROGRAM		B
Mode	Piggyback	
Rate	200 mL/hr	
VTBI	100 mL	
Duration	00:30 hr : min	
Enter value using keypad 		
Program Options	Therapy	Cancel/Back
▲	▲	▲

At end of Piggyback delivery, with Callback enabled for the line, Callback alarm is issued.

- 4) Press (SILENCE) to clear alarm.

A	PUMPING	STOPPED	B
5.5	Rate mL/hr	200	
0.3	Vol Inf mL	100	
Callback Line B 			
	A	B	Options/ Vol Inf
▲	▲	▲	▲

6.4 Possible Non-Delivery Programmed

NOTE: Whenever a valid [START] key is pressed, the device checks the delivery program(s) for non-delivery conditions (such as Line B Piggyback without Line A or delayed start) that could permit a period of non-delivery. If so, the display presents this warning screen.

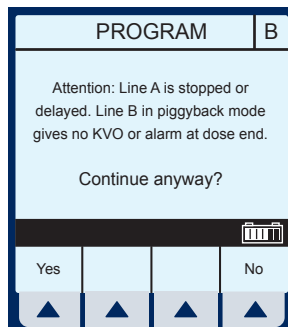

- 1) Select ▲ [YES] to continue with delivery. Or, select ▲ [NO] to cancel.

6.5 Using the Standby Feature

Standby is a feature that enables the clinician to program the infuser up to 23:59 minutes in advance of starting.

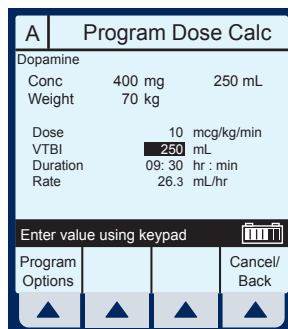

- 1) If Line A is infusing, select ▲ [A] (or ▲ [B]) to access program screen of line to be placed on Standby.
- 2) Select ▲ [PROGRAM OPTIONS].
- 3) Select ▲ [STANDBY].

- 4) **Confirm the information displayed is correct, then select ▲ [YES] to place program on Standby mode.**

NOTE: This example screen shows a Dose Calculation Program with a Standby. It looks similar to the Program Confirmation screen with the substitution of “Put delivery in Standby” replacing “Confirm Program”. Selecting ▲ [YES] confirms both the Program and the Standby.

A	Program Dose Calc		
Delivery will be:			
Dose	10 mcg/kg/min		
Drug	Dopamine		
Conc	400 mg	250 mL	
Weight	70 kg		
Put delivery in Standby?			
Yes			No
▲	▲	▲	▲

- 5) **Press (START) to remove Standby and start the program.**

A	STANDBY	STOPPED	B
Dopamine			
Dose Calculation			
26.3	Rate	0	
	mL/hr		
0	Vol Inf	0	
	mL		
10	mcg/kg/min		
	A	B	Options/ Vol Inf
▲	▲	▲	▲

6.6 Select Option - Volumes Infused, Pressure/Post Infusion Rate, and Lighting/Contrast

- 1) To select the Options screen, select

▲ [OPTIONS/VOL INF].

A	PUMPING	STOPPED	B
5.5	Rate mL/hr	0	
393	Vol Inf mL	0	
	A	B	Options/ Vol Inf
▲	▲	▲	▲

- 2) Use ▲▼ to highlight an option.

- 3) Select ▲ [CHOOSE] to select the Volumes Infused screen.

A	OPTIONS	B	
Release 11.x - xx/xx/xx			
Volumes Infused			
Pressure/Post Infusion Rate			
Lighting/Contrast			
Select, then Choose			
		Choose	Back
▲	▲	▲	▲

This will bring up the Volumes Infused screen which defaults to Total Volume.

- 4) Use ▲▼ to scroll to Line A or B.

A	OPTIONS	B	
Volumes Infused			
Line A	0	mL	
Line B	0	mL	
Total Vol	393	mL	
Press CLEAR to clear value			
		Enter	Cancel/ Back
▲	▲	▲	▲

- 5) To reset Line A (or B) Volume Infused, use ▲▼ to highlight and press .

A	OPTIONS	B
Volumes Infused		
Line A	0 mL	
Line B	0 mL	
Total Vol	393 mL	
Press CLEAR to clear value 		
	Enter	Cancel/ Back
▲	▲	▲

- 6) To restore the cleared quantity, select ▲ [CANCEL/BACK].

- 7) To reset all volumes, use ▲▼ to highlight Total Vol, then press .

A	OPTIONS	B
Volumes Infused		
Line A	0 mL	
Line B	0 mL	
Total Vol	0 mL	
Press CLEAR to clear value 		
	Enter	Cancel/ Back
▲	▲	▲

- 8) To restore all quantities, select ▲ [CANCEL/BACK] softkey.

- 9) When clearing of quantities is completed, select ▲ [ENTER] to return to the Main Delivery screen.

- 10) Select ▲ [OPTIONS/VOL INF] from the Main Delivery screen to return to the Options screen.

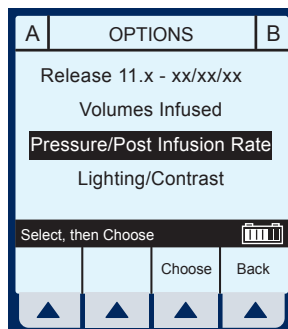

- 11) Use ▼ to highlight the Pressure/Post Infusion Rate option.

- 12) Select ▲ [CHOOSE] to continue.

NOTE: Prior to changing Pressure/Post Infusion Rate, infuser must be stopped.

- 13) Use ▲▼ to highlight Continue Rate or Distal Pressure Limit field.

- 14) Continue Rate allows a choice when VTBI is completed. Select ▲ [KVO/RATE].

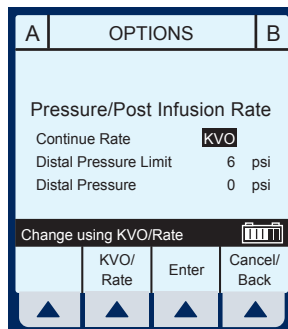

- **KVO** - The infuser will revert to a fixed KVO of 1 mL/hr or the last programmed Rate, whichever is less.
- **Rate** - The infuser will continue at the Rate programmed.

NOTE: Option will be for both line A and line B selections.

- 15) To change Distal Pressure Limit when highlighted, enter value between 1 and 15 psi.
- 16) Select ▲ [ENTER] to keep changes and return to the Main Delivery screen, or ▲ [CANCEL/BACK] to restore original values Options screen.

NOTE: Continue Rate default of KVO or Rate is a biomedical setting and must be configured as described in the Technical Service Manual.

- 17) Select ▲ [OPTIONS/VOL INF] from the Main Delivery screen to return to the Options screen.

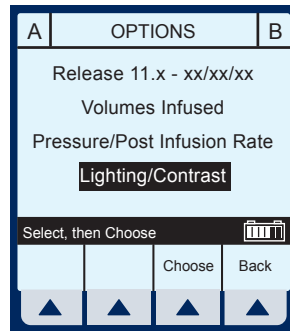

- 18) Use ▼ key to highlight Lighting/Contrast Option.

- 19) Select ▲ [CHOOSE] to continue.

- 20) Press ▲▼ key to highlight Backlight Intensity or Display Contrast.

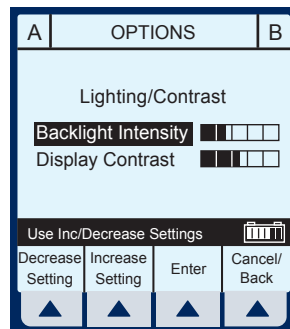

- 21) While viewing display for desired effect, select either ▲ [INCREASE SETTING] or ▲ [DECREASE SETTING] to change level.

- 22) Select ▲ **[ENTER]** to keep change(s) and return to the Main Delivery screen, or ▲ **[CANCEL/BACK]** to restore previous values and return to the Options screen.

6.7 Variable Rate Cap

Variable Rate Cap is a biomed programmable item to set the maximum rate values to be accepted by the device. The clinician cannot change it once biomed has programmed it.

6.8 Examples of Automatic Calculation

AT STARTUP

Initial programming allows the clinician to enter two of the three programming parameters (Rate, VTBI, or Duration) and the third is automatically calculated. (*Refer to table below*)

1st Action	2nd Action	<i>[AUTOCALC]</i>
enter RATE	enter VTBI	<i>[DURATION]</i>
enter VTBI	enter DURATION	<i>[RATE]</i>
enter RATE	enter DURATION	<i>[VTBI]</i>

WHILE RUNNING (*TITRATION*)

Changing two parameters after startup of the infusion will allow for the re-calculation of the third parameter.

NOTE: VTBI will not be re-calculated if the Rate and Duration are changed. VTBI must be cleared and then the new VTBI re-entered. The new VTBI will automatically calculate a new Rate.

1st Action	2nd Action	[AUTOCALC]
change RATE	keep VTBI	[DURATION]
change RATE	change VTBI	[DURATION]
change VTBI	keep RATE	[DURATION]
change DURATION	keep VTBI	[RATE]
change VTBI	change DURATION	[RATE]
change RATE	change DURATION	Recalculates [RATE] based on previous VTBI and new DURATION

AT KVO

Audible KVO alarm will sound, clinician will need to re-set the appropriate settings.

1st Action	2nd Action	[AUTOCALC]
enter VTBI	keep RATE	[DURATION]
enter DURATION	keep RATE	[VTBI]
change RATE	enter VTBI	[DURATION]
enter DURATION	enter VTBI	[DURATION]
enter VTBI	enter DURATION	[RATE]
change RATE	change DURATION	[VTBI]

7) Alarms and Troubleshooting

7.1 Warning Messages

MESSAGE	POSSIBLE CAUSE	CORRECTIVE ACTION
Stop delivery then turn off	Attempting to turn the infuser off while a delivery is in progress.	Stop all lines, then turn infuser off.
Warning: Replace Battery	The battery current charge is greater than 200 mA/hr. The battery voltage is less than the depleted threshold and charge level is higher than the low charge threshold.	Battery needs to be replaced.
Warning: Charger Service	The charging circuitry is not behaving as expected (charge voltage is not changing) and can reduce battery life.	Silence key is pressed.
Warning: Low Battery	Infuser not plugged in to AC power.	Plug into AC power, only about 30 minutes of battery life remains.

NOTE: Other error and warning messages will occur when appropriate for the current selection context. For instance, when a change to a required parameter would result in clearing some delivery values, the warning message will appear when that field is selected. When an input error has just been made, the three quick beeps of an Invalid Key Warning will sound and an appropriate warning message will be shown to explain the problem. All such messages will be cleared or replaced by another message upon the next valid input key press.

7.2 Response to Alarms

1. Disable Lockout by confirming back switch is in the down position or press the decimal key followed by 9, 6, and 3 on the keypad.
2. Press [SILENCE] key.
3. Identify/Observe Alarm condition.
4. Correct Alarm condition (see following tables).
5. Press [START] to resume infusion.

NOTE: Alarm messages begin with an alphanumeric code for tracking purposes only. If troubleshooting does not correct the problem, record the code number and contact technical support.

GENERAL ALARMS

CODE	MESSAGE	POSSIBLE CAUSE	CORRECTIVE ACTION
N100	Unrecognized cassette	Attempting to use unrecognized cassette.	Turn off or insert recognized cassette.
N101	No Action Alarm	Infuser programming incomplete.	Press [START] or continue programming.
N102	Infuser Idle 2 Minutes	Pump is ON without operator input. Standby time has elapsed.	Begin programming or turn infuser OFF. Re-enter all programmed data.
N103	Memory Failure	The infuser did not accept the previous programmed data.	Re-enter all programmed data.
N230	Prox Air, Backprime	When the total proximal air detected exceeds the limit.	Check for clamps or empty containers on line A or B. Correct as necessary. Backprime into line B tubing or syringe.
N180, N181, N186	Distal Occlusion	Distal line kinked, IV site clotted or positional, pressure limit set too low.	Check distal tubing, check IV site, reset pressure limit. <i>See page 1-14 for detailed instructions for avoiding a bolus following a distal occlusion.</i>
N187	Neg Distal Occlusion	Pump too high above patient or defective set.	Lower infuser or replace set.
N233, N234	Distal Air	When air is detected at the distal sensor and exceeds the limit.	Remove and reprime cassette using standard technique.
N250	Door open while pumping	Pump door opened while operating.	Close door with cassette inserted.

CODE	MESSAGE	POSSIBLE CAUSE	CORRECTIVE ACTION
N251	Cassette Test Failure	Faulty cassette, proximal or distal occlusion or air in cassette detected at start up.	Check clamps, manually reprime set, close door. Backprime into line B tubing or syringe if appropriate. If alarm recurs on retest, replace set. If alarm repeats, replace infuser.
N252	Depleted Battery	Too much time on battery power.	Plug into AC (mains) power.
N253	Hard lockout Violation	The use of the [STOP] key during delivery, or opening the door, while lockout is enabled.	Unlock lockout switch.
N254	Hard lockout Enabled	Pressing of any key except [STOP] during delivery while any alarm is active and lockout is enabled.	Unlock lockout switch.
N255	Soft lockout Violation	The use of the [STOP] key during delivery, or opening the door, while lockout is enabled.	Unlock lockout by pressing the decimal key, followed by 9, 6, and 3 on the keypad.
N256	Soft lockout Enabled	Pressing of any key except [STOP] during delivery while any alarm is active and lockout is enabled.	Unlock lockout by pressing the decimal key, followed by 9, 6, and 3 on the keypad.

LINE A ALARMS

CODE	MESSAGE	POSSIBLE CAUSE	CORRECTIVE ACTION
N105	Callback Line A	Alarm programmed by user. Change in delivery for Loading Dose to Maintenance Step or for any step in Multistep therapy provided the step is not the last step.	Press [SILENCE].
N161	Line A VTBI complete	VTBI complete on line A.	Program new VTBI.
N185	Prox Occl A At Startup	Proximal line obstructed, line A container (or syringe) disconnected or obstructed during non-delivery (startup).	Examine line A for kinks or closed clamps. If there are closed clamps, open the clamps. Then, open and close door. Continue programming. Replace set if problem persists. If clamps are not opened prior to completion of cassette test, peak proximal occlusion may recur. For syringe, select ▲ [BACKPRIME].
N184, N190, N191	Prox Occl A / Air	Proximal line obstructed, line A container disconnect or obstruction.	Examine line A for kinks, closed clamps, or air in cassette.
N232	Prox Air A, Backprime	When proximal air detected exceeds the limit for the line.	Check for clamps, or empty container. Correct as necessary. Backprime into line B tubing or syringe.

LINE B ALARMS

CODE	MESSAGE	POSSIBLE CAUSE	CORRECTIVE ACTION
N104	Callback Line B	Alarm programmed by user. Change in delivery for piggyback delivery, Loading Dose to Maintenance Step, or for any step in "Multistep" therapy provided the step is not the last step.	Press [SILENCE].
N160	Line B VTBI complete	VTBI complete on line B.	Program new VTBI.
N183	Prox Occl B At Startup	Proximal line obstructed, line B container (or syringe) disconnected or obstructed during non-delivery (startup).	Examine line B for kinks or closed clamps. If there are closed clamps, open the clamps. Then, open and close door. Continue programming. Replace set if problem persists. If clamps are not opened prior to completion of cassette test, peak proximal occlusion may recur. For syringe, select ▲ [BACKPRIME].
N182, N188, N189	Prox Occl B / Air	Proximal line obstructed, line B container disconnected or obstructed.	Examine line B for kinks, closed clamps, or air in cassette. Occlusion caused by empty container, backprime into line B tubing or syringe.
N231	Prox Air B, Backprime	When proximal air detected exceeds the limit for the line.	Check for clamps, or empty container. Correct as necessary. Backprime into line B tubing or syringe.

MALFUNCTIONS

CODE	MESSAGE	POSSIBLE CAUSE	CORRECTIVE ACTION
E300 or higher	Malfunction	A failure has occurred in the infuser's internal systems.	Record Malfunction error code. Pump must be turned OFF to clear malfunction. If alarm malfunction repeats, replace infuser.

NOTES

8) Maintenance and Storage

8.1 Cleaning, Maintenance, and Storage

The cleaning, maintenance, and storage of the Plum A+ are described in this section.

CLEANING AND SANITIZING

For proper maintenance of the Plum A+, observe the following cleaning and sanitizing guidelines.

Establish a routine weekly schedule for cleaning the infuser. To clean, proceed as follows:

- **Turn the Plum A+ off using the [ON/OFF] switch**
- **Disconnect from AC (mains) power**

The exposed surfaces of the Plum A+ may be cleaned with a lint-free cloth dampened by one of the recommended cleaning solutions in the following list or mild, nonabrasive soapy water.

Clean the cassette door with a soft, lint-free cloth, dampened with one of the cleaning agents listed in the following table, or a mild solution of soapy water. Use a small non-abrasive brush to aid in cleaning the infusion system housing and subsystem chassis components. To thoroughly clean the cassette receptacle, disengage the cassette door from the door latch by pressing the door release tab.

CAUTION: DO NOT ALLOW CLEANING SOLUTIONS TO SATURATE THE AIR-IN-LINE DETECTORS OR ENTER THE DEVICE WHEN CLEANING THE AIR-IN-LINE DETECTORS.

CLEANING SOLUTION	MANUFACTURER	PREPARATION
Coverage™HBV	Steris Corporation, A division of Calgon Vestal Laboratories	Per manufacturer's recommendation
Formula C™	Diversey Corporation	Per manufacturer's recommendation
Dispatch™	Caltech Industries	Per manufacturer's recommendation
Precise™	Caltech Industries	Per manufacturer's recommendation
Household bleach	Various	Per hospital procedures; do not exceed one part bleach in ten parts water
Manu-Klenz™	Calgon Vestal Laboratories	Per manufacturer's recommendation
Sporicidin™	Sporicidin International	Per manufacturer's recommendation
Super Edisonite™	S. M. Edison Co.	Per manufacturer's recommendation

The rubber pad on the Plum A+3 pole clamp, as well as the IV poles for both instruments, may be cleaned using isopropyl alcohol.

On a routine basis, clean all of the elements behind the cassette door using cotton-tipped swabs saturated with cleaning solution. The cassette door may be unlatched from the door handle to facilitate cleaning.

To unlatch the cassette door from its handle, tilt the device back, open the cassette door, then push the door release tab to open the door fully.

CAUTION: TO AVOID MECHANICAL OR ELECTRONIC DAMAGE, DO NOT IMMERSE THE PLUM A+ IN ANY FLUIDS OR CLEANING SOLUTIONS.

CAUTION: DO NOT SPRAY CLEANING SOLUTIONS TOWARD ANY OPENING IN THE INSTRUMENT.

CAUTION: CERTAIN CLEANING AND SANITIZING SOLUTIONS MAY SLOWLY DEGRADE COMPONENTS MADE FROM SOME PLASTIC MATERIALS. USING ABRASIVE CLEANERS OR CLEANING SOLUTIONS NOT RECOMMENDED BY HOSPIRA MAY RESULT IN PRODUCT DAMAGE. DO NOT USE COMPOUNDS CONTAINING COMBINATIONS OF ISOPROPYL ALCOHOL AND DIMETHYL BENZYL AMMONIUM CHLORIDE.

CAUTION: NEVER USE SHARP OBJECTS SUCH AS FINGERNAILS, PAPER CLIPS, OR NEEDLES TO CLEAN ANY PART OF THE INFUSER.

CAUTION: DO NOT STERILIZE BY HEAT, STEAM, ETHYLENE OXIDE (ETO), OR RADIATION.

CAUTION: TO AVOID INFUSER DAMAGE, CLEANING SOLUTIONS SHOULD ONLY BE USED AS DIRECTED. THE DISINFECTING PROPERTIES OF CLEANING SOLUTIONS VARY; CONSULT THE MANUFACTURER FOR SPECIFIC INFORMATION.

BATTERY MAINTENANCE

CAUTION: DO NOT OPERATE THE INFUSER ON PATIENTS WITH THE BATTERY REMOVED. USE OF A PROPERLY MAINTAINED AND CHARGED BATTERY HELPS CONFIRM PROPER OPERATION.

CAUTION: IF THE LOW-BATTERY ALARM SOUNDS, CONNECT TO AC (MAINS) POWER IMMEDIATELY.

The Plum A+ is battery powered for emergency backup and temporary portable operation. A fully charged, new battery provides six hours of operation at 125 mL/hr or 500 mL total volume delivered, whichever occurs first.

NOTE: For optimum battery life, the Plum A+ should be operated on battery power for six continuous hours at least once every six months and then charged for a minimum of eight hours.

The battery charges whenever connected to AC (mains) power. If the infuser is switched OFF, recharge takes approximately six hours. Recharge takes longer if the infuser is turned ON.

As a general rule, the more often the battery is partially discharged and recharged, the sooner it will need to be replaced. Consult a qualified biomedical technician for battery replacement if necessary.

To maintain maximum battery charge and to prolong battery life, connect the infuser to AC (mains) power whenever possible.

STORAGE

To prolong the life of the Plum A+, observe the following storage precautions:

- **Store away from excessive heat, cold, and humidity**
- **Store connected to AC (mains) power**
- **Switch the infuser OFF using the [ON/OFF] key**

SERVICE

All servicing or adjustments to the Plum A+ should be referred to qualified technical personnel. A technical service manual may be ordered from the local Hospira sales office.

9) Specifications

NOTE: Specification information applies to both systems (Plum A+ and Plum A+3) unless otherwise noted.

PHYSICAL

Dimensions -

Plum A+: Approximately 8" X 8" X 6", excluding pole clamp protrusion and power cord storage.

Plum A+3: Approximately 19" X 15" X 14", including pole clamp, barcode wand holder, and power cord.

Weight- Plum A+: Approximately 9.5 lbs. with battery.

Plum A+3: Approximately 28 lbs. with (3) batteries.

Casing: High-impact plastic.

ELECTRICAL

Power Requirements -

Plum A+: 100-120V, 50-60 Hz, 50 VA

Plum A+3: 100-120V, 50-60 Hz, 150 VA

Fuses: Internal and non-replaceable

Power Cord: Hospital-grade AC cord. 10 ft long, with transparent plug and retainer plate.

Battery- Plum A+: One sealed, lead-acid, rechargeable 6 V battery, internal to device.

Plum A+3: Three sealed, lead-acid, rechargeable 6 V batteries, internal to device.

Battery Life: With a new fully charged battery, the infuser shall operate for a minimum of six hours at 125 mL/hr or less, or deliver 500 mL at 126 mL/hr or greater on one line.

Recharge: The battery charges whenever the infuser(s) is connected to AC power. The recharge time is approximately six hours with the device operating at 125 mL/hr on one line.

Electrical Leakage:	Meets ANSI/AAMI ES1-1993 standard: Safe Current Limits for Electro-medical Apparatus.
NURSE-CALL System:	NURSE-CALL alarm is factory set for Normally- Open (NO) Contact the Technical Services Center to make an internal adjustment to change the device from Normally-Open (NO) to Normally Closed (NC) system.
Circuitry Ratings:	Voltage-30 VDC Max Current- 0.25 Amps Max Contact Rating- 3 Watts Max

VTBI RANGE

VTBI Range:	0.1 to 99.9 mL (in 0.1 mL increments) 100 to 9999 mL (in 1 mL increments)
--------------------	--

ENVIRONMENT

Operating Temperature:	5° to 40° C
Storage Temperature:	-20° to 60° C
Atmospheric Pressure:	0 - 10,000 feet (0 - 3,000m) or equivalent pressure
Relative Humidity:	10 - 90% (40° C Max)

DELIVERY RATE RANGE

Lines A and B:	0.1 - 99.9 mL/hr (in 0.1 mL increments) 100 - 999 mL/hr (in 1 mL increments)
Concurrent Delivery:	0.5 mL/hr minimum for each line
PlumSet:	500 mL/hr cumulative (A+B) maximum
KVO:	1.0 mL/hr or the last primary delivery rate, whichever is less

AIR-IN-LINE ALARM

PlumSet (Distal): Bolus 0.1 mL or larger.
Cumulative 0.25 mL out of 4.9 mL.

PlumSet (Proximal): Bolus at 0.5 mL, Total 1.0 mL

OCCLUSION ALARM AND LIMITS

Distal Occlusion: The DISTAL OCCLUSION alarm sounds after the distal set tubing or set outlet fitting becomes occluded.

Proximal Occlusion: The PROXIMAL OCCLUSION alarm sounds if the tubing proximal to the cassette becomes occluded.

Distal Pressure Limit (without alarm): 1 to 15 psig. The maximum pressure is user-selectable. Factory default setting is 6 psig.

Maximum Infusion Pressure: 20 psig

TIME TO DETECT DOWNSTREAM OCCLUSIONS

RATE	OCCLUSION ALARM PRESSURE SETTING	TYPICAL TIME TO ALARM (MACRO)	MAXIMUM TIME TO ALARM (MACRO)
25 mL/hr	6 psig	38 seconds	47 seconds
	15 psig	98 seconds	106 seconds
1 mL/hr	6 psig	17 minutes	22 minutes
	15 psig	45 minutes	49 minutes

* Baseline backpressure is 0 psig *

BOLUS VOLUME RELEASED AFTER DOWNSTREAM OCCLUSIONS ARE CORRECTED

RATE	OCCLUSION ALARM PRESSURE SETTING	TYPICAL BOLUS VOLUME (MACRO)	MAXIMUM BOLUS VOLUME (MACRO)
25 mL/hr	6 psig	0.23 mL	0.28 mL
	15 psig	0.55 mL	0.63 mL
1 mL/hr	6 psig	0.24 mL	0.30 mL
	15 psig	0.59 mL	0.70 mL

* Baseline backpressure is 0 psig *

DELIVERY ACCURACY

The Plum A+ Infuser was designed and manufactured to maintain a volumetric delivery rate error of the total fluid delivered of less than or equal to $\pm 5\%$ over the course of 48 hours at a programmed rate of 1 to 999 mL/hr during normal operating conditions. For use of the device at rates below 1 mL/hr, the delivery rate error is less than or equal to $\pm 10\%$.

Backpressure Effect- Positive backpressure on the distal line may affect delivery accuracy by no more than 0.5% per psig (2% per psig for rates between 0.1 and 0.9 mL/hr) for backpressures up to

15 psig. A typical deviation under these conditions is 0.3%. Negative backpressure may affect delivery accuracy no more than 2% for pressures up to -2 psig (56 inches of water). A typical deviation under these conditions is 0.3%.

Filling Head Effect- Variations in filling head (such as container height) may affect delivery accuracy by no more than 2% for variations in the range -15 to +28 inches. A typical deviation under these conditions is 0.5%.

Concurrent Delivery Effect- When both lines (A and B) are delivering, the ratio of delivery for the fluid with the lowest rate may be affected by as much as 5% for ratios up to 9 to 1. For higher ratios, the absolute percentage of delivery for the lowest rate may be affected by no more than 0.5%. When air is present in the bubble trap, the absolute percentage of delivery for the lowest rate may be affected by up to 2.0%. When variations in container height are present, the absolute percentage of delivery for the lowest rate may be affected by up to 2.5% for up to 24 inches of container height differences.

ENTERAL AND HIGH VISCOSITY FLUIDS EFFECTS

System delivery accuracy limits for each Enteral and High Viscosity Fluid, such as those listed in the following table, can be degraded by an additional maximum of 5%. System accuracy for Enteral Fluids is defined only for rates of 1 to 200 mL/hr, with no suspended air in the solution, and using an Hospira Plum enteral set.

ENTERAL/HIGH VISCOSITY FLUIDS
Dextrose 20% to 50% concentration
Isomil™ Powder
Similac™ Powder
Ensure Plus™ HN
Twocal™ HN
Jevity™

TRUMPET CURVES

The Trumpet Curve Graphs following the Example show representative maximum and minimum percent flow rate deviation from the programmed rate over time. This information was developed in accordance with IEC 60601-2-24: 1998, Sub-Clause 50.102. Refer to this standard for detailed information.

How to read a Trumpet Curve Graph (Refer to example on the following page): The graphs following the Example plot flow rates at 30 second intervals for the first 2 hours and for the 96th hour of delivery. The graph plots mean delivery rate error (Average of 3 infusers) for the 2nd hour and the 96th hour as a straight line. The graph also presents maximum and minimum average delivery rate error for this interval plotted by averaging delivery errors over intervals of 2, 5, 11, 19 and 31 minutes ("Trumpet Curve").

Note that at extremely low flow rates (that is, 0.1–0.3 mL/hr) and at non-standard negative back pressures (-1 psi), the accuracy error rate can be up to $\pm 25\%$.

EXAMPLE

From the Trumpet Curve Graph sample that follows, find the 5 minute interval (A) at the horizontal axis and read the corresponding points (B) and (C) on the vertical axis. The values are approximately +2.8% and -0.5%.

This means that at the rate of 25 mL/hr the average maximum flow rate fluctuation for any 5 minute time interval during the 2nd hour of operation was within the limits of +2.8% and -0.5% from the nominal rate. The average delivery rate error over the entire 2nd hour was +1.6% (D).

For other time intervals look at other points at the horizontal axis and determine corresponding limits as above.

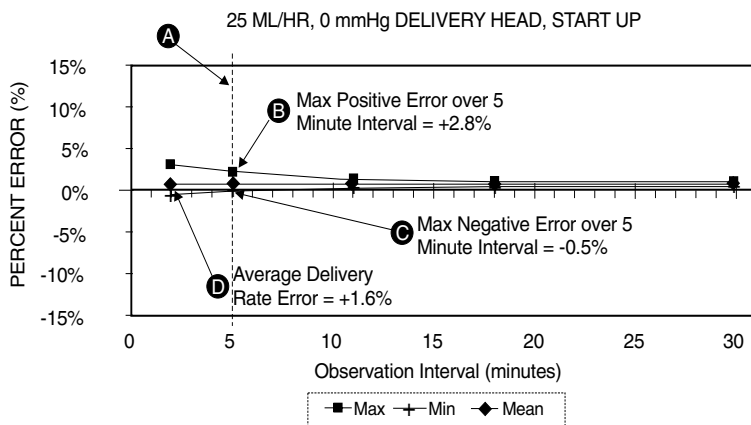

A trained professional can use the resulting graphs to select an infuser with the appropriate startup and flow characteristics to suit the clinical application.

NOTE: As an example of how the trumpet curves can be used, consider the maximum and minimum deviations at the 5 minute average interval. The upper curve provides the maximum expected delivery rate error over a 5 minute interval, the lower curve provides the minimum expected delivery rate error over a 5 minute interval. An example would be Dopamine administered at 5 $\mu\text{g}/\text{kg}/\text{min}$. At 5 minutes, the average drug delivery error would be within the range of +2.8% and -0.5% of the expected nominal rate.

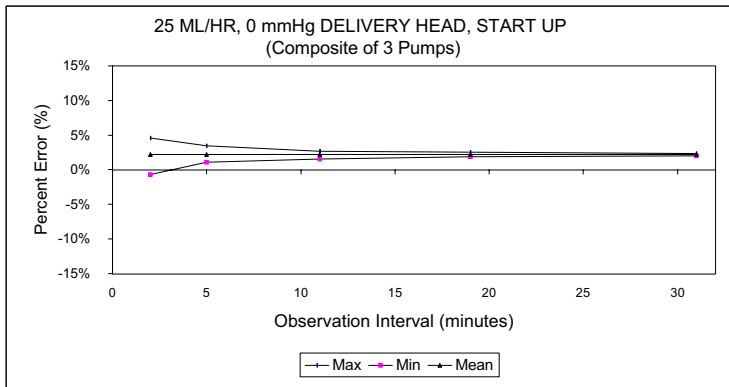
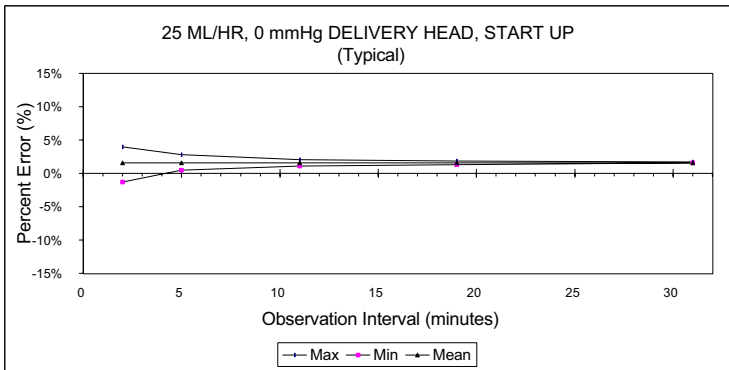
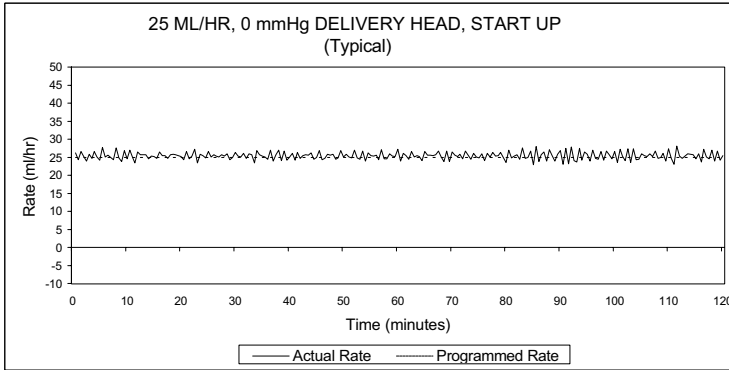

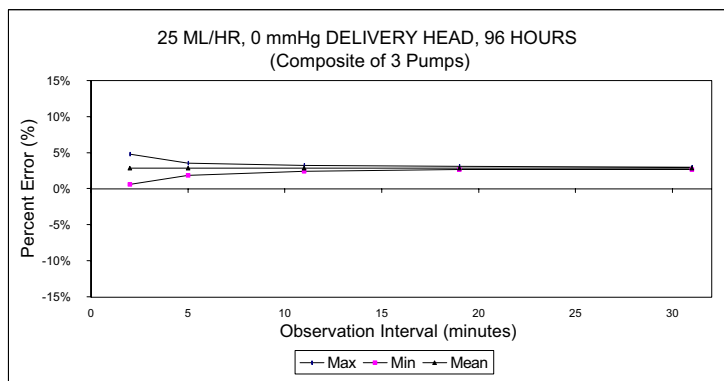
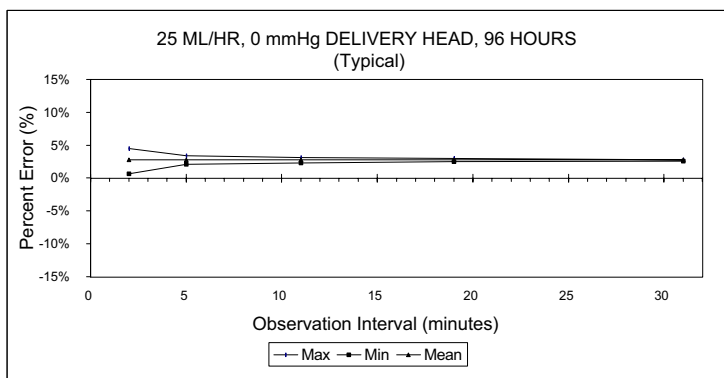
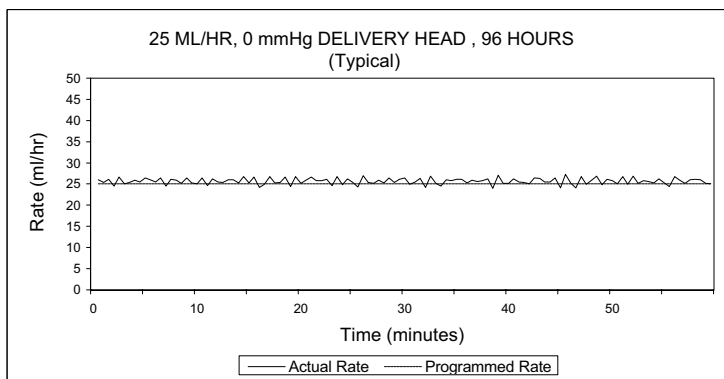

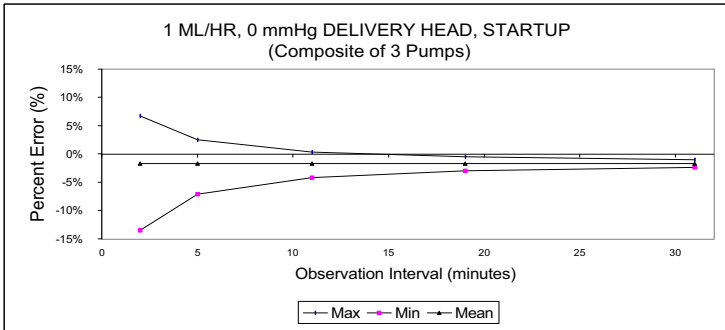
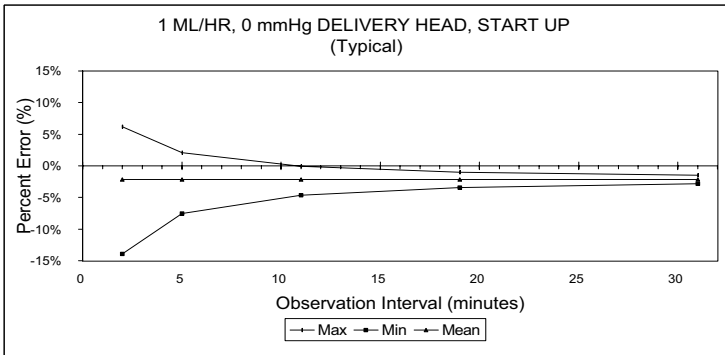
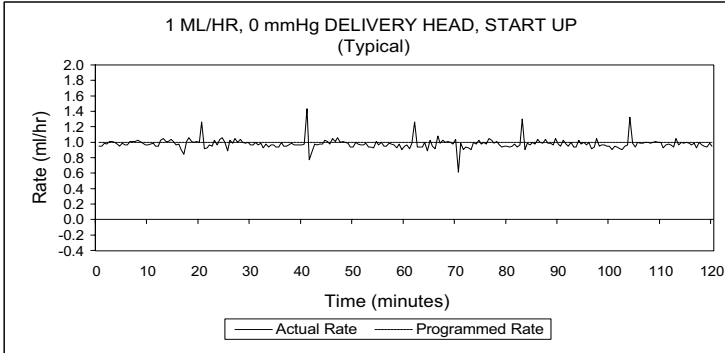

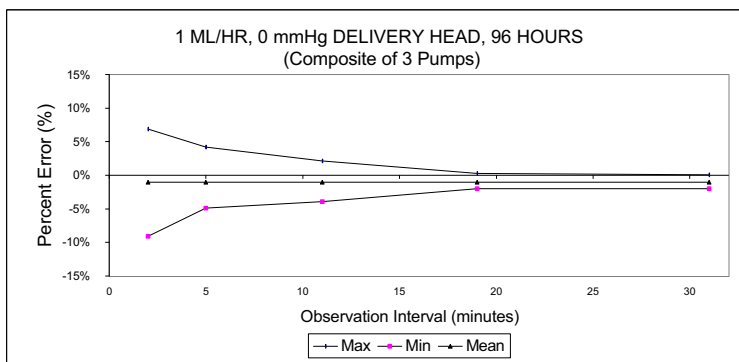
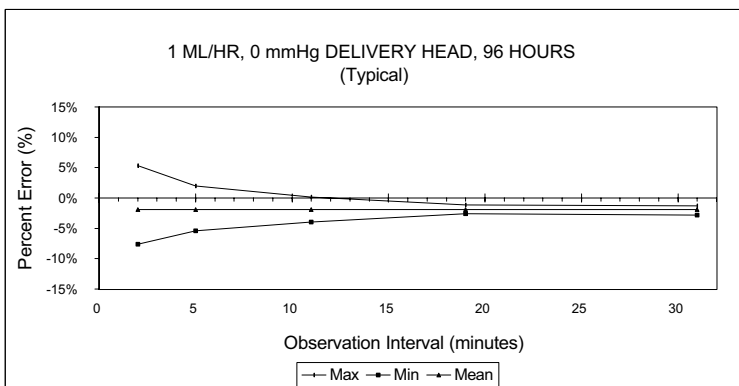
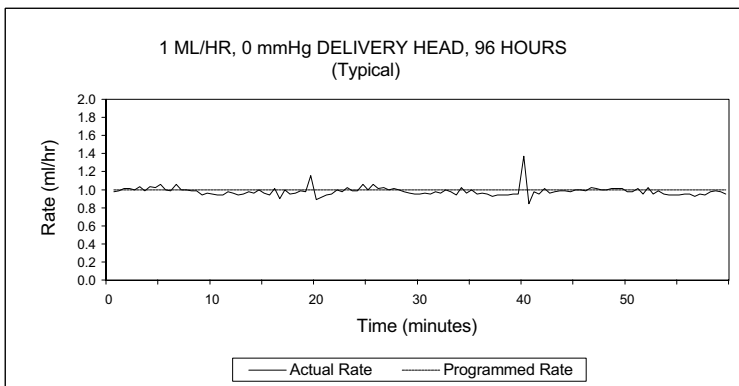

NOTES

10) Supplies and Accessories

10.1 Administration Fluids

ADMINISTRATION FLUIDS

- All parenteral fluids
- Whole blood
- Blood fractions

ENTERAL AND HIGH VISCOSITY FLUIDS

- Dextrose 20% to 50% concentration
- Isomil Powder
- Similac Powder
- Ensure Plus HN
- TwoCal HN
- Packed red cells

CONTAINERS

- Dual Chamber Parenteral flexible container (Nutrimix™)
- Large Volume Parenteral flexible plastic containers, including premixed
- Large Volume Parenteral glass containers, including premixed and nutritional
- Part Fill Parenteral flexible plastic containers, including ADD-Vantage™
- Part Fill Parenteral glass containers
- Small Volume Parenterals
- Syringes (may require special adapters)
- Top Filled Enteral bags
- Ready to hang Enteral solution containers

10.2 Accessories

- **Syringe Adaptor - List# 11986-48**
- **Mini Pole - List# 12096-04**
- **Secondary Container Support - List# 12095-03**
- **Tandem Carrier - List# 12270-01**
- **Plum A+3 IV Pole (upright) - 12577-04-01**
- **Plum A+3 IV Pole (base) - 12576-04-01**

11)

Warranty

Subject to the terms and conditions herein, Hospira, Inc., herein referred to as Hospira, warrants that (a) the product shall conform to Hospira's standard specifications and be free from defects in material and workmanship under normal use and service for a period of one year after purchase, and (b) the replaceable battery shall be free from defects in material and workmanship under normal use and service for a period of 90 days after purchase. Hospira makes no other warranties, express or implied, as to merchantability, fitness for a particular purpose, or any other matter.

Purchaser's exclusive remedy shall be, at Hospira's option, the repair or replacement of the product. In no event shall Hospira's liability arising out of any cause whatsoever (whether such cause be based in contract, negligence, strict liability, other tort, or otherwise) exceed the price of such product, and in no event shall Hospira be liable for incidental, consequential, or special damages or losses or for lost business, revenues, or profits. Warranty product returned to Hospira must be properly packaged and sent freight prepaid.

The foregoing warranty shall be void in the event the product has been misused, damaged, altered, or used other than in accordance with product manuals so as, in Hospira's judgment, to affect its stability or reliability, or in the event the serial number or lot number has been altered, effaced, or removed.

The foregoing warranty shall also be void in the event any person, including the Purchaser, performs or attempts to perform any major repair or other service on the product without having been trained by an authorized representative of Hospira and using Hospira documentation and approved spare parts. For purposes of the preceding sentence, "major repair or other service" means any repair or service other than the replacement of accessory items such as batteries and detachable mains power cords.

In providing any parts for repair or service of the product, Hospira shall have no responsibility or liability for the actions or inactions of the person performing such repair or service, regardless of whether such person has been trained to perform such repair or service. It is understood and acknowledged that any person other than a Hospira representative performing repair or service is not an authorized agent of Hospira.

12)**Drug List**

Use drug manufacturer recommendations for IV administration when using the Plum A+ infuser.

DRUG NAME	DEFAULT DOSE RATE	DEFAULT CONCENTRATION
No Drug Selected	mL/hr	N/A
Abciximab	mcg/kg/min	mg/mL
Acyclovir	mL/hr	N/A
Albumin	mL/hr	N/A
Aldesleukin	mL/hr	N/A
Alfentanil	mcg/kg/min	mcg/mL
Alteplase (rt-PA)	mg/kg/hr	mg/mL
Amikacin	mL/hr	N/A
Aminocaproic Acid	grams/hr	grams/mL
Aminophylline	mg/hr	mg/mL
Amiodarone	mg/min	mg/mL
Amphotericin B	mL/hr	N/A
Ampicillin-sulbactam	mL/hr	N/A
Analgesic	mL/hr	N/A
Antibiotic	mL/hr	N/A
Atracurium	mL/hr	N/A
Azithromycin	mL/hr	N/A
Bleomycin	mL/hr	N/A
Blood Products	mL/hr	N/A
Bretylium	mg/min	mg/mL
Carboplatin	mL/hr	N/A
Cefazolin	mL/hr	N/A
Cefapime	mL/hr	N/A

DRUG NAME	DEFAULT DOSE RATE	DEFAULT CONCENTRATION
Cefoperazone	mL/hr	N/A
Cefotaxime	mL/hr	N/A
Cefotetan	mL/hr	N/A
Cefoxitin	mL/hr	N/A
Ceftazidime	mL/hr	N/A
Ceftizoxime	mL/hr	N/A
Ceftriaxone	mL/hr	N/A
Cefuroxime	mL/hr	N/A
Chemotherapy	mL/hr	N/A
Cimetidine	mL/hr	N/A
Ciprofloxacin	mL/hr	N/A
Cisplatin	mL/hr	N/A
Clindamycin	mL/hr	N/A
Co-trimoxazole	mL/hr	N/A
Cyclophosphamide	mL/hr	N/A
Cyclosporine	mL/hr	N/A
Cytarabine	mL/hr	N/A
Dexmedetomidine HCl	mcg/kg/hr	mcg/mL
Diltiazem	mg/hr	mg/mL
Dobutamine	mcg/kg/min	mg/mL
Docetaxel	mL/hr	N/A
Dopamine	mcg/kg/min	mg/mL
Doxorubicin	mL/hr	N/A
Epinephrine	mcg/min	mg/mL
Epoprostenol	ng/kg/min	mg/mL
Eptifibatide	mcg/kg/min	mg/mL
Erythromycin	mL/hr	N/A
Esmolol	mcg/kg/min	mg/mL

DRUG NAME	DEFAULT DOSE RATE	DEFAULT CONCENTRATION
Etomidate	mL/hr	N/A
Etoposide	mL/hr	N/A
Famotidine	mL/hr	N/A
Fentanyl	mL/hr	N/A
Fluconazole	mL/hr	N/A
Flumazenil	mL/hr	N/A
Fluorouracil	mL/hr	N/A
Furosemide	mL/hr	N/A
Gatifloxacin	mL/hr	N/A
Gentamicin	mL/hr	N/A
Heparin	units/kg/hr	units/mL
Hetastarch/NaCl	mL/hr	N/A
Hextend	mL/hr	N/A
Hydromorphone	mL/hr	N/A
Ifosfamide	mL/hr	N/A
Imipenem Cilastatin	mL/hr	N/A
Immune Globulin IV	mL/hr	N/A
Insulin	units/hr	units/mL
Isoproterenol HCl	mL/hr	N/A
Labetalol	mg/min	mg/mL
Lepirudin	mg/kg/hr	mg/mL
Leucovorin	mL/hr	N/A
Levofloxacin	mL/hr	N/A
Lidocaine	mg/min	grams/mL
Lipids	mL/hr	N/A
Lorazepam	mL/hr	N/A
Magnesium Infusion	grams/hr	grams/mL
Mannitol	grams/hr	grams/mL

DRUG NAME	DEFAULT DOSE RATE	DEFAULT CONCENTRATION
Mesna	mL/hr	N/A
Methohexital	mL/hr	N/A
Methotrexate	mL/hr	N/A
Methylprednisolone	mL/hr	N/A
Metoclopramide	mL/hr	N/A
Metronidazole	mL/hr	N/A
Midazolam	mL/hr	N/A
Milrinone	mcg/kg/min	mg/mL
Morphine	mg/hr	mg/mL
Nafcillin	mL/hr	N/A
Naloxone	mL/hr	N/A
Nitroglycerin	mcg/min	mg/mL
Nitroprusside	mcg/kg/min	mg/mL
Norepinephrine	mcg/min	mg/mL
Ofloxacin	mL/hr	N/A
Ondansetron	mL/hr	N/A
Oxacillin	mL/hr	N/A
Oxytocin	mUn/min	units/mL
Paclitaxel	mL/hr	N/A
Pancuronium	mg/kg/hr	mg/mL
Pantoprazole	mg/min	mg/mL
Penicillin	mL/hr	N/A
Pentobarbital	mL/hr	N/A
Phenylephrine	mcg/min	mg/mL
Piperacillin-bactam	mL/hr	N/A
Potassium Infusion	mEq/hr	mEq/mL
Procainamide	mg/min	grams/mL
Propofol	mcg/kg/min	mg/mL

DRUG NAME	DEFAULT DOSE RATE	DEFAULT CONCENTRATION
Quinolone	mL/hr	N/A
Ranitidine	mL/hr	N/A
Streptokinase	units/hr	units/mL
Teniposide	mL/hr	N/A
Theophylline	mg/kg/hr	mg/mL
Ticar-calvulanate	mL/hr	N/A
Tirofiban	mcg/kg/min	mg/mL
Tobramycin	mL/hr	N/A
TPN	mL/hr	N/A
Urokinase	mL/hr	N/A
Vancomycin	mL/hr	N/A
Vecuronium	mL/hr	N/A
Verapamil	mL/hr	N/A
Vincristine	mL/hr	N/A

NOTES

Plum A+ Infusion Systems

For customer service within the United States, contact:

1-877-9-HOSPIRA (1-877-946-7747)

For technical assistance, product return authorization, and to order parts, accessories, or manuals within the United States, call Hospira, Inc. Advanced Knowledge Center:

1-800-241-4002

To order parts using the online eCatalog, download technical publications, technical training courses, and additional services, visit the website at:







www.hospiraparts.com

Outside the U.S., contact your local Hospira, Inc. sales office.

CAUTION: FEDERAL (USA) LAW RESTRICTS THIS INFUSER TO SALE BY OR ON THE ORDER OF A PHYSICIAN OR OTHER LICENSED PRACTITIONER.

WARNING

POSSIBLE EXPLOSION HAZARD EXISTS IF THE INFUSER IS USED IN THE PRESENCE OF FLAMMABLE ANESTHETICS.

 Type CF	Per IEC 60601-1 F-Type Applied Part complying with the highest degree of protection against electric shock. Type CF Applied Parts are those parts suitable for direct cardiac application.		Fragile, Handle with Care
IPX1	Protection against vertically falling water drops.		Keep Dry
Class 1	Mains supply equipment using protective earth.		This Way Up
 UL 60601-1 CSA 601.1 MCN 160992	The 'C' and 'US' indicators adjacent to the CSA Mark signify that the product has been evaluated to the applicable CSA and ANSI/UL Standards, for use in Canada and the U.S., respectively. This 'US' indicator includes products eligible to bear the 'NRTL' indicator. NRTL, i.e., National Recognized Testing Laboratory, is a designation granted by the U.S. Occupational Safety and Health Administration (OSHA) to laboratories which have been recognized to perform certification to U.S. Standards.		Temperature Limitation
			Attention: Consult Accompanying Documents or Caution